

GENERAL AND APPLIED PLANT PHYSIOLOGY

Volume XXXI, No. 3-4, 2005

Bulgarian Academy of Sciences

R. Yasodha, R. Sumathi, M. Dasgupta, K. Gurumurthi. Isolation of high quality DNA for AFLP amplification in <i>Casuarina equisetifolia</i> L.	127
Mitko I. Dimitrov, Anthony A. Donchev, Kolyo G. Kolev and Christo D. Christov. Jasmonic acid levels and seed development in sunflower (<i>Helianthus annuus</i> L.)	135
Nadejda Babalakova, Svetlana Boycheva, Snejka Rocheva. Effects of short-term treatment with ionic and chelated copper on membrane redox-activity induction in roots of iron - deficient cucumber plants	143
Bárbara Albuquerque, Fernando C. Lidon, Maria G. Barreiro. A case study of tendral winter melons (<i>Cucumis melo</i> L.) postharvest senescence	157
R. Gopi, R. Sridharan, R. Somasundaram, G.M. Alagu Lakshmanan and R. Panneerselvam. Growth and photosynthetic characteristics as affected by triazoles in <i>Amorphophallus campanulatus</i> Blume	171
K. B. Mishra and R. Gopal. Study of laser-induced fluorescence signatures from leaves of wheat seedlings growing under cadmium stress	181
Petranka Yonova and Gergana Stoilkova. Antisenescence effect of 2-pyridylureas with un- and cyclic- ureido group	197
Jos Puthur. Influence of light intensity on growth and crop productivity of <i>Vanilla planifolia</i> Andr.	215
Aisha Saleem Khan and Najma Yaqub Chaudhry. Morphogenetic effects of mercury in <i>Lagenaria siceraria</i> (Mol) Standl and their partial reversal by exogenous auxin	225

F. Broetto, J.A. Marchese, M. Leonardo, M. Regina. Fungal elicitor-mediated changes in polyamine content, phenylalanine-ammonia lyase and peroxidase activities in bean cell culture	235
--	-----

Brief communication

Bárbara Albuquerque, Fernando C. Lidon and A. Eduardo Leitão. Ascorbic acid quantification in melon samples – the importance of the extraction medium for HPLC analysis	247
---	-----

ISOLATION OF HIGH QUALITY DNA FOR AFLP AMPLIFICATION IN *CASUARINA EQUISETIFOLIA* L.

R. Yasodha*, **R. Sumathi**, **M. Dasgupta**, **K. Gurumurthi**

Division of Plant Biotechnology, Institute of Forest Genetics and Tree Breeding, Coimbatore – 641 002, INDIA

Received 14 October 2005

Summary. High quality DNA was isolated from *Casuarina equisetifolia* which is widely planted in tropics and subtropics for its multiple utilities. Two commonly used methods, CTAB based and the commercially supplied DNeasy™ Plant Mini Kit (QIAGEN GmbH, Germany) were tested for their efficiency in isolating high quantity and quality DNA to be utilized for AFLP analysis. The CTAB based protocol was modified by introducing additional steps and manufacturer's protocol was followed for the commercial kit. DNA yield and purity were monitored by gel electrophoresis and by determining absorbance under UV (A260/A280 and A260/A230). Both ratios were between 1.9 and 2.1, indicating the absence of contaminating metabolites. The average DNA yield obtained from 100 mg needle tissue using the CTAB based protocol and the commercial kit was 17 mg and 6 mg, respectively. Further, the purity of DNA was assessed by enzymatic digestion with *EcoRI* and *HindIII* and the DNA was also tested for suitability by AFLP-PCR analysis. A unique AFLP pattern was achieved for the five ortets tested showing the utility of DNA for fingerprint studies. Based on the quantity of isolated DNA, the CTAB based method is recommended for *C. equisetifolia* DNA extraction and it can be utilized for other *Casuarina* species with high content of fiber and phenolic compounds.

Keywords: *C. equisetifolia*, DNA isolation, restriction digestion, AFLP, CTAB method

Abbreviations: AFLP - amplified fragment length polymorphism; CTAB – cetyltrimethyl ammonium bromide; EDTA – ethylenediamine tetraacetic

* Corresponding author, email: yasodha@ifgtb.res.in

acid; TE buffer – 10 mM Tris-HCl, pH 7.5, 1mM EDTA, pH 8.0; TBE buffer- 90 mM Tris base, 90 mM boric acid, 2 mM EDTA, pH 8.2.

INTRODUCTION

Casuarina equisetifolia is a multipurpose plantation species, best suited in the agrarian ecosystems in South and South East Asia. A short rotation period, ability to improve soil fertility and ready marketability are the major attractions for this species. Clonal plantations of this species are common in India, China, Vietnam and Egypt that are raised from the out performing phenotypes selected from provenance trials. International provenance trials were established in 20 tropical and subtropical countries for evaluating variations existing within the species (Pinyopusarerk et al., 2004). Breeding programs were established through selection of best provenances and establishment breeding populations (Nicodemus et al, 2001). DNA markers are regarded as the best tools to accelerate breeding in tree species and marker-assisted breeding have been reported for many tropical trees (Ho et al., 2002). Among the dominant markers, amplified fragment length polymorphism (AFLP) is regarded as the best system for monitoring breeding programs in forest trees, construction of high-density genetic maps and quantitative trait loci maps because of its high throughput nature and better genetic resolution.

In *C. equisetifolia* and *C. junghuhniana* provenances variations were assessed using random amplified polymorphic DNA (RAPD) and inter simple sequence repeat (ISSR) markers (Ho et al., 2002; Ho et al, 2004). RAPD variations were used to identify introgressive hybridization in *C. equisetifolia* (Ho et al, 2002). Genetic analysis of *Casuarina* species (and *Allocasuarina*) and clonal fingerprinting of *C. equisetifolia* were performed with ISSR and Fluorescent-ISSR markers (Yasodha et al., 2004). No reports about the use of AFLP for members of the family *Casuarinaceae* are available.

AFLP technique requires isolation of DNA with high purity for restriction digestion. Isolation of DNA free of metabolites particularly, polysaccharides and phenolic compounds is most essential because these compounds can irreversibly bind to nucleic acids during extraction steps (Varadarajan and Prakash, 1991), may interfere with DNA isolation, cloning, characterization (Bousquet et al., 1990) and inhibit the activity of DNA modifying enzymes (Pandey et al., 1996; Abdulova et al., 2002). Recent studies have indicated that extraction of DNA is not always simple or routine and the published protocols are not necessarily reproducible for all species (Doulis et al., 2000; Lin et al., 2001).

Higher amounts of polyphenols particularly tannins, fibrous nature and xerophytic adaptations of *Casuarina* needles make the DNA isolation difficult in this species. Needle tissues are known to be difficult for DNA extraction and were classi-

fied as “recalcitrant” or “hard” tissues (Csaikl et al., 1998). Therefore, in the present study, two different methods, which are routinely used for many plant species, were tested to isolate DNA from needles of *Casuarina*. DNA was further subjected to restriction digestion analysis and AFLP-PCR amplifications.

MATERIALS AND METHODS

Plant material

Needle samples from five ortets of 5-year-old hedged *C.equisetifolia* were used for DNA isolation. The growing tips of the needles were collected and the fresh sample was washed in double distilled water, dried on a paper towel for 1-2 min and stored at -20° C.

DNA isolation

DNA was isolated using two routinely used extraction protocols (Doyle and Doyle, 1990 and Qiagen DNeasy Plant Mini kit). In both methods, 100 mg needle tissue was ground to a fine powder with liquid nitrogen in a pre-chilled mortar.

Method 1

The first attempt to isolate DNA utilized a modified method of Doyle and Doyle (1990). The tissue powder was transferred immediately into pre-warmed (65° C) extraction buffer (2 % w/v CTAB, 1.4 M NaCl, 20 mM Na_2EDTA , 100 mM Tris-HCl, pH 8.0, 0.2% b-mercaptoethanol) and incubated for 40 min at 65° C in a water bath with gentle mixing per every 10 min. Chloroform: Isoamyl alcohol (24:1) extraction was carried out twice and the DNA was precipitated by addition of 8.0 ml of ice-cold 2-propanol and placed at -20° C for one hour. DNA was processed to remove RNAs as described earlier (Doyle and Doyle, 1990) and the pellet was dissolved in 100 ml of double distilled water. Further purification of DNA was carried out twice by extracting with TE buffered phenol/chloroform/isoamyl alcohol (25:24:1). Thirty μl of 3.0 M sodium acetate was added, vortexed for 2 s followed by the addition of 650 μl of ice-cold ethanol and vortexed again for 2 s. The DNA sample was placed at -20° C for 30 min. DNA was washed with 70% ethanol, air-dried and resuspended in 25 ml TE buffer (10 mM Tris-HCl, pH 7.4, 1 mM Na_2EDTA) and stored at -20° C until analysis.

Method 2

The second method utilized a commercial kit to extract DNA, the DNeasy Plant Mini Kit (Qiagen, Germany, Cat. No.69103). Isolation procedures were followed accord-

ing to the manufacturer's instructions. In the final step DNA was eluted with 75 ml TE buffer and stored at -20°C .

Evaluation of nucleic acids

Each DNA solution was assayed for UV absorption spectrum using a UV/VIS spectrophotometer (NanoDrop Technologies, USA). The absorbance was recorded at 230, 260 and 280 nm to estimate yield and quality. Further, *C. equisetifolia* genomic DNA (140.0 ng) was digested with 5 units each of *EcoRI* and *HindIII* (MBI, Fermentas, Lithuania) in the recommended buffer at 37°C for 4 h. DNA digestion was assayed by visual inspection after agarose gel (0.8%) electrophoresis.

AFLP Analysis

AFLP products were generated with 200 ng genomic DNA, following the protocol of Vos et al. (1995) using the AFLP Analysis System I (Gibco- BRL, Life Technologies, USA) kit. Genomic DNA (5.0 ml) was double restriction digested for 6 h at 37°C with 1.25 units each of *EcoRI* and *MseI* in a 25 ml volume. After heat inactivation for 15 min at 70°C , restriction site derived adapters were ligated for 2 h at 20°C with 24 ml of Adapter-ligation solution and 1 unit of T_4 Ligase. The ligation mix was diluted with an equal volume of TE buffer and pre-amplified with adapter-derived primers having an additional (+1) nucleotide at the 3' end and amplified using 20 cycles of 30 s denaturation at 94°C , 60 s annealing at 56°C and 60 s extension at 72°C . The reaction products were diluted 30-fold with TE buffer. The second amplification was performed with a combination of *EcoRI* and *MseI* primers that had three selective nucleotides each. Primer combinations used included: E-ACG / M-CAG; E-ACG / M-CAC and E-ACG / M-CAA. The second amplification was performed in a 20 ml final volume with 10 cycles of 94°C for 60 s, 65°C for 60 s with a decrease of -1.0°C per cycle, and 72°C for 90 s followed by 30 cycles of 94°C for 30 s, 56°C for 60 s and 72°C for 60 s. AFLP reaction products were separated in 6% (w/v) denaturing polyacrylamide in 1X TBE buffer and visualized by silver staining using the method described by Briard et al. (2000).

RESULTS AND DISCUSSION

The source tissue from which DNA is extracted plays a critical role in determining DNA quantity and quality (Weising et al., 1994; Abdulova et al., 2002). Mature *Casuarina* needles consist of extensive lignified and fibrous tissue and high tannin content interfering with DNA isolation. Rapidly growing young needles which must maximize photosynthetic efficiency and growth may not invest in lignified structural tissue and therefore, they serve as an ideal starting material for DNA isolation.

The total yield of DNA isolated by method 1 and method 2 was 17.0 mg/100mg fresh weight tissue and 6.0 mg/100mg fresh weight tissue, respectively (Table 1). The purity of isolated DNA was assessed by the UV absorbance ratios. The A260nm/A230 nm ratio was 2.09 and 2.18 while the A260 nm/A280 nm ratio was 2.10 and 1.93 for DNA isolated by method 1 and 2, respectively, indicating the absence of major contaminants. DNA obtained using the two methods appeared on the agarose gel as a single band of average size approximately 23 kb and with no trailing of denatured DNA (Figure 1). Further, the complete digestion of DNA using *Eco*RI and *Hind*III (an enzyme particularly inhibited by the presence of polysaccharides) showed that the isolated DNA was free of polysaccharides and other contaminating inhibitory substances (Figure 1). Similarly, pure and high DNA yield from needle tissues was reported by Doulis et al (2000) in *Cupressus sempervirens* and Stange et al (1998) in *Pinus radiata* with modified CTAB and Qiagen commercial kit. CTAB-based extraction methods have proved to yield good quality DNA and are frequently used for DNA isolation from needles of many forest tree species like *Pinus radiata* (Stange et al., 1998), *Taxus wallichiana* (Khanuja et al., 1999), *Ulmus glabra*, *Abies alba*, *Pinus sylvestris* (Csaikl et al., 1998) and *Picea abies* (Scheepers et al., 1997).

Table 1. DNA yield obtained by two extraction methods

Method	Quantity (mg) /100mg fresh tissue \pm SD	A260/A280 \pm SD	A260/A230 \pm SD
Method 1	17.0 \pm 3.9	2.10 \pm 0.904	2.09 \pm 0.569
Method 2	6.0 \pm 2.5	1.93 \pm 0.573	2.18 \pm 0.513

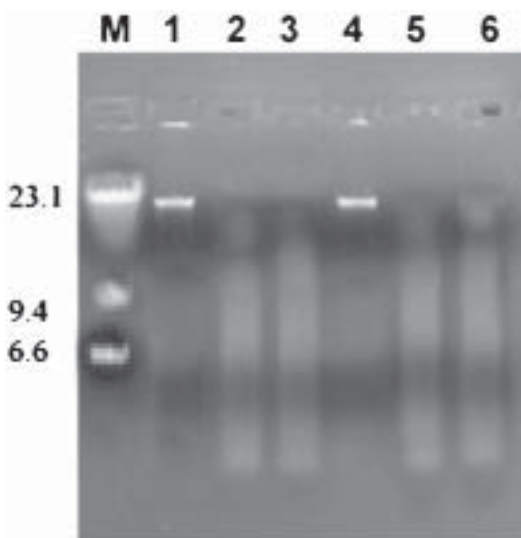

Figure1. DNA isolated from *C. equisetifolia*. Lanes: M-Lambda-HindIII digest, 1-DNA isolated following method 1, 2&3-Method 1 DNA digested with *Eco* RI and *Hind* III, 4- DNA isolated following method 2, 5&6-Method 2 DNA digested with *Eco* RI and *Hind* III



AFLP procedure is influenced by the quantity and quality of the DNA preparation requiring more complex DNA purification methods (Henry, 2001). Hence, DNA isolated from *C. equisetifolia* was subjected to AFLP analysis to evaluate the suitability of DNA for fingerprinting studies. The procedure described for the amplification of AFLP markers in *C. equisetifolia* was tested with five different individuals and unique AFLP fingerprint patterns for each individual were obtained (Figure 2). Silver staining of the polyacrylamide gels was found to be advantageous for AFLP in carrot (Briard et al., 2000). In *C. equisetifolia* about 20-30 bands were observed with few faint bands which were excluded from the data analysis.

In conclusion, both methods used in the present study produced pure DNA suitable for AFLP analysis. Method 1, a CTAB based modified protocol of Doyle and Doyle (1990) yielded high-quantity DNA and can be recommended for *C. equisetifolia* DNA extraction. Casuarinas have needles with high content of fiber and phenolic compounds. Therefore, this protocol can be adapted for other *Casuarina* species.

Acknowledgements: This work was supported by a grant from the Department of Biotechnology, Government of India.

Figure 2. AFLP-PCR in *C. equisetifolia* using DNA isolated by method 1. Lanes 1-5: Five ortets, M - DNA ladder

References

- Abdulova, G., E.D. Ananiev, P. Grozdanov, 2002. Isolation and purification of nuclear DNA from excised cotyledons of *Cucurbita pepo* L. (zucchini). *Bulg. J. Plant Physiol.*, 28, 3–11.
- Pinyopusarerk, K., A. Kalinganire, E.R. Williams, K.M. Aken 2004. Evaluation of International Provenance Trials of *Casuarina equisetifolia*. ACIAR Technical Report No 58, Australian Centre for International Agricultural Research, GPO Box 1571, Canberra, ACT 2601, 106.
- Bousquet, J., L. Simon, M. Lalonde, 1990. DNA amplification from vegetative and sexual tissues of trees using polymerase chain reaction. *Can. J. For. Res.*, 20, 254–257.
- Briard, M., V. Le Clerc, D. Grzebelus, D. Senalik, P.W. Simon, 2000. Modified protocols for rapid carrot genomic DNA extraction and AFLP analysis using silver stain or radioisotopes. *Plant Mol. Biol. Rep.*, 18, 235–241.
- Csaikl, U.M., H. Bastian, R. Brettschneider, S. Gauch, A. Meir, M. Schauerte, F. Scholz, C. Sperisen, B. Vornam, B. Ziegenhagen, 1998. Comparative Analysis of Different DNA Extraction Protocols: A Fast, Universal Maxi-Preparation of High Quality Plant DNA for Genetic Evaluation and Phylogenetic Studies. *Plant Mol. Biol. Rep.*, 16, 69–86.
- Doulis, A.G., A.L. Harfouche, F. A. Aravanopoulos, 2000. Rapid, High Quality DNA Isolation from Cypress (*Cupressus sempervirens* L.) Needles and Optimization of the RAPD Marker Technique. *Plant Mol. Biol. Rep.*, 17, 1–14.
- Doyle, J.J., J.L. Doyle, 1990. Isolation of plant DNA from fresh tissue. *Focus* 12, 13–15.
- Henry, R.J., 2001. *Plant Genotyping: The DNA fingerprinting of Plants*, CABI Publishing, New York.
- Ho, K.Y, C.H. Ou, J.C. Yang, J.Y. Hsiao, 2002. An assessment of DNA polymorphisms and genetic relation-ships of *Casuarina equisetifolia* using RAPD markers. *Bot. Bull. Acad. Sin.*, 43, 93–98.
- Ho, K.Y, J.C. Yang, S.L. Deng, T.H. Chen, 2004. Assessment of genetic variation and relationships of international provenances of *Casuarina junghuhniana* using ISSR. *Taiwan. J. For. Sci.*, 19(1), 79–88.
- Khanuja, S.P.S., A.K. Shasany, M.P. Darokar, S. Kumar, 1999. Rapid Isolation of DNA from Dry and Fresh Samples of Plants Producing Large Amounts of Secondary Metabolites and Essential Oils. *Plant Mol. Biol. Rep.*, 17, 1–7.
- Lin, R.C., Z. S. Ding, L. B. Li, T.Y. Kuang, 2001. A Rapid and Efficient DNA Minipreparation Suitable for Screening Transgenic Plants. *Plant Mol. Biol. Rep.*, 19, 379a–379e.
- Pandey, R.N., R.P. Adams, L.E. Flournoy, 1996. Inhibition of random amplified polymorphic DNAs (RAPDs) by plant polysaccharides. *Plant Mol. Biol. Rep.*, 14(1), 17–22.
- Scheepers, D., M.C. Eloy, M. Briquet, 1997. Use of RAPD patterns for clone verification and in studying provenance relationships in Norway spruce (*Picea abies*). *Theor. Appl. Genet.*, 94, 480–485.
- Stange C, D. Prehn, A.J. Patricio, 1998. Isolation of *Pinus radiata* Genomic DNA Suitable for RAPD Analysis. *Plant Mol. Biol. Rep.*, 16, 1–8.
- Varadarajan, C. S., C. S Prakash, 1991. A rapid and efficient method for the extraction of total DNA from the sweet potato and its related species. *Plant Mol. Biol. Rep.*, 9, 6–12.

- Vos P, R. Hogers, M. Bleeker, M. Rijans, T. van der Lee, M. Hornes, A. Frijters, J. Pot, J. Peleman, M. Kuiper, M. Zabeau, 1995. A new technique for DNA fingerprinting. *Nucl Acid Res*, 23, 4407–4414.
- Weising, K., H. Nybom, K. Wolff, W. Meyer, 1994. DNA fingerprinting in plants and fungi. CRC Press, London.
- Yasodha R, M. Kathirvel, R. Sumathi, K. Gurumurthi, Sunil Archak, J. Nagaraju, 2004. Genetic analyses of Casuarinas using ISSR-PCR and FISSR-PCR markers. *Genetica* 122, 161-172.

JASMONIC ACID LEVELS AND SEED DEVELOPMENT IN SUNFLOWER (*HELIANTHUS ANNUUS* L.)

Mitko I. Dimitrov¹, Anthony A. Donchev¹, Kolyo G. Kolev² and Christo D. Christov²

¹Institute of Biophysics, Bulgarian Academy of Sciences, 1113 Sofia, Bulgaria

²Institute of Plant Physiology, Bulgarian Academy of Sciences, 1113 Sofia, Bulgaria

Received 2 October 2005

Summary. Using gas–mass chromatography analyses (GS-MS) we have determined the endogenous levels of jasmonic acid (JA) in developing sunflower seeds. The level of JA was higher in the early phases of seed development. We have registered a maximum on day 5 after pollination. Spraying of plants with JA at the time of flowering induced marked changes in protein content. Five days after treatment total protein content decreased by 33% whereas 15 day after flowering it exceeded the control values by 33%. In addition, the results from the SDS-polyacrylamide gel electrophoresis (SDS-PAGE) revealed qualitative and quantitative changes in the spectra of soluble proteins.

Key words: electrophoresis, jasmonic acid, protein, seed development, sunflower.

INTRODUCTION

Jasmonic acid and its methyl ester belong to the plant growth regulators modulating various developmental processes in plants (Koda, 1992; Wasternack and Hause, 2002; Ananiev et al., 2003; Ananieva and Ananiev, 2003). On the other hand, JA is an essential element in the signal transduction pathways in response to different kinds of abiotic and biotic stress (Sembdner and Parthier, 1993; Wasternack and Parthier, 1997; Wasternack and Hause, 2002). Jasmonates cause dramatic alterations in gene expression. It has been shown that JA promotes pollen maturation and dehiscence

* Corresponding author, e-mail: mitkod@obzor.bio21.bas.bg

during the flowering thus ensuring successful fertilization and seed set (Sanders et al., 2000; Devoto and Turner, 2003).

When applied exogenously jasmonates affect the level of vegetative storage proteins, VSPs) (for reviews see Staswick, 1994; Wasternack and Parthier, 1997). The participation of JA in protein metabolism of reproductive organs is obscure; the level of endogenous JA there remains to be determined more accurately.

Our previous investigations have shown that treatment of sunflower plants with JA during flowering increases the seed yield. In extracts from seeds of treated plants alterations of the proportion of fatty acids in favor of linoleic acid in particular has been registered (Christov et al., 1993).

In the present work, we have determined the level of endogenous JA and JA derivatives as well as the effect of the exogenously applied JA on protein profile of sunflower seeds during the earliest stages of development.

MATERIALS AND METHODS

Sunflower plants of cv. *Peredovic* were grown on alluvial-meadow soil pH 5.6 in the Experimental Field of the Institute of Plant Physiology, Sofia. The fertilizer application was done taking into consideration the conditions for optimal root nutrition, such as availability of slightly hydrolyzable nitrogen and mobile phosphorus and potassium (Pandev et al., 1981). Plants were sprayed with 50 :M JA in the middle of flowering.

The analysis of endogenous JA content was carried out with kernels harvested at the end of flowering and by days 5 and 15 after pollination. The extraction medium contained 80% methanol (v/v). The homogenates obtained were filtered through a layer of Celite, frozen, thawed up, centrifuged and fractioned in a medium of acidified ethyl acetate with pH 2.5. The fractions received were subsequently resolved by column chromatography on DEAE-Sephadex A-25 using a discontinuous gradient of acetic acid against 80% methanol. Aliquots of the fractions obtained were tested for inhibitory activity using the method of Tan-ginbozu rice seedlings. Endogenous JA was identified in the fraction eluted by 0.25 N acetic acid, subsequently passed through C₁₈ reversed-phase cartridges and purified further by thin-layer chromatography on silicagel GF₂₅₄ plate run in a mixture of n-hexane:ethyl acetate:acetic acid, 6:4:1. Spots containing jasmonates were visualized by anisaldehyde reagent. The endogenous JA derivatives were methylated with ethereal diazomethane and passed through a gas chromatograph (Hewlett-Packard) supplemented with mass-spectrometer (GC-MS).

The protein analyses were carried out with kernels harvested at days 5 and 15 after pollination. The extraction medium contained 2% Triton-X-100 (w/v), 0.15 M KCl and 0.1 M Na-phosphate buffer, pH 6.85. Aliquots of 0.5 g were homogenized

in 7.5 ml of the medium by stirring 30 min at 40°C. The homogenate was clarified by centrifugation for 30 min at 15000 rounds per minute (centrifuge Janetzki K-24) and concentrated up to 0.5 ml using an “Amicon” devise for ultra-filtration, supplied with a membrane DIAFLO^R YM-2. The sample was rinsed with four volumes of deionized water and was kept frozen at -25°C. After thawing the sample was again centrifuged. For removal of Triton-X-100 the protein was precipitated in 20% trichloroacetic acid, rinsed twice with chilled ethanol and dissolved in the appropriate buffer.

Absorbance spectra were registered using a spectrophotometer “SPECORD UV-VIS” (Karl Zeiss, Jena, Germany). For spectral measurements aliquots of the samples were diluted with distilled water in a ratio 1:5. Protein concentrations were determined by the absorbance registered at 260 and 280 nm using the relation of Darbre and Clamp (1989).

SDS-PAGE was performed according to Fling and Gregerson (1986). A laboratory build apparatus with gel-plate dimensions of 83/79/1 mm was used. Separating gels contained gradient of acrylamide of 8-25% or 12-25% (w/v). The sampling conditions were according to Piccioni et al. (1982). The sample buffer contained lithium dodecyl sulfate (LDS) instead of sodium dodecyl sulfate (SDS). 15 ml of samples with 0.1-0.5 mg ml⁻¹ protein were loaded on the gel slots. Electrophoresis was run using a LKB 1809 Power Supply. The protein bands were stained with Coomassie R-250 “Bio-Rad” and scanned on a “Shimadzu CS-930” apparatus using a regime of transition light at 580 nm.

RESULTS

Endogenous JA was identified in developing seeds of *Helianthus annuus* L. 5 days after flowering using the established procedures (Grabner et al., 1976; Dathe et al., 1989). At the early stage of purification we used the Tan-ginbozu rice seedlings bioassay for identification of the JA inhibitory activity which was registered in the fraction eluted by 0.25 N acetic acid (data not shown). The methylated derivative of JA was analyzed by GC-MS. The mass spectra of ionization states obtained from the 0.25 N acetic acid fraction resolved (2) and that of methyl di-2-epijasmone as a standard (1) are shown in Fig.1. Library algorithm calculations revealed higher than 88% identity between the spectrum of putative endogenous JA and that of the standard. The gas chromatograms relative to plant materials harvested at the end of flowering (1), on day 5 after pollination (2) and on day 15 after pollination (3) are shown in Fig.2. The peak areas are indicative for the level of endogenous JA. At the end of flowering it was relatively low in comparison with later stages of seed development (Fig.2, 1). The maximum value of endogenous JA content was registered on day 5 after pollination (Fig.2). During the next stage of seed development JA levels decreased (Fig.2, 3). These results confirm previously reported data showing high lev-

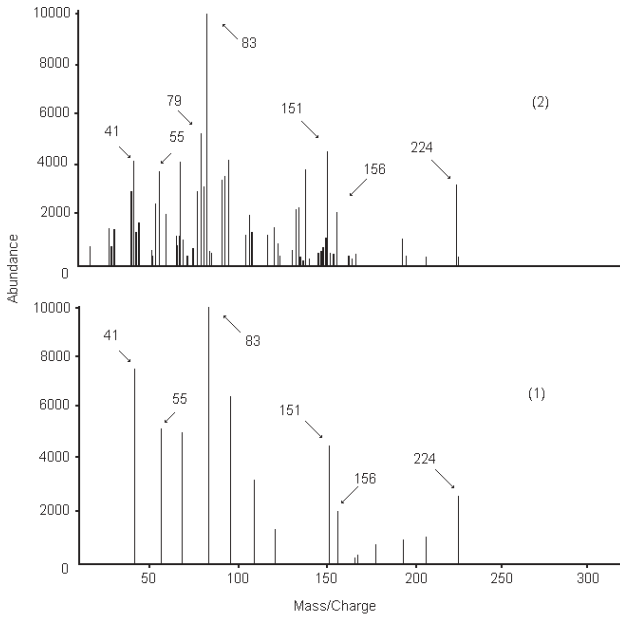

Fig.1. Comparison of mass spectra of JA-standard (1) and endogenous JA isolated from seeds of *Helianthus annuus L* (2). Both samples were methylated prior to GC-MC.

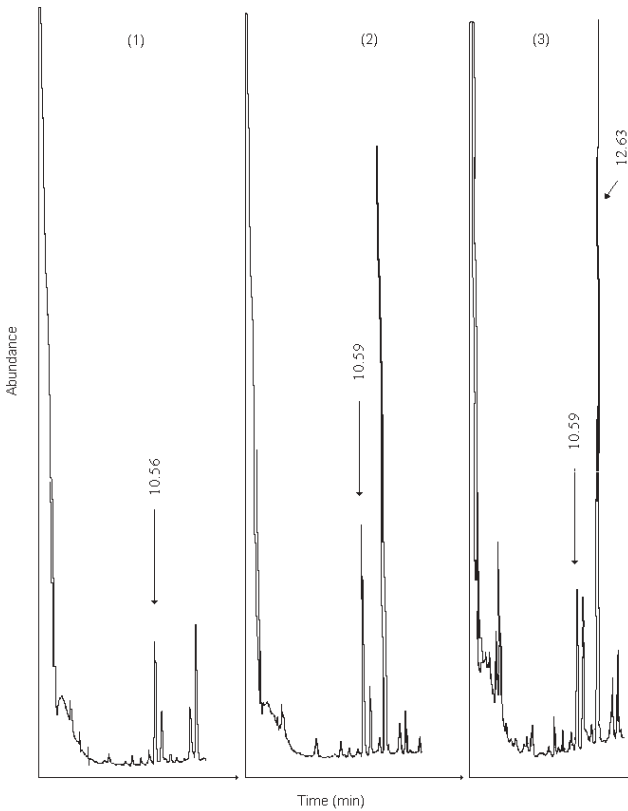

Fig.2. Gas chromatography of JA-derivative compounds isolated from seeds of *Helianthus annuus L*, harvested as follows: (1) at the end of flowering; (2) 5 days after pollination; (3) 15 days after pollination.

els of JA in the pericarp, hilum and testa tissues of soybean during seed development (Creelman and Mullet, 1995; Lopez et al., 1987).

Spraying the plants with 50 μ M JA resulted in distinctive variations in protein content of developing seeds. Fig.3 shows the UV-absorption spectra of protein extracts at different stages of seed development. JA applied at the end of flowering induced substantial changes in protein content which were time-dependent. Protein content measured on day 5 after JA treatment was approximately 33% lower when compared with the control. Fifteen days after spraying, however, protein content increased and even exceeded the control values by 33%. In addition, some small decrease in protein levels of the respective two controls (5- and 15-day-old control plants) was also registered. The spectral picture was typical for protein solutions with predominant presence of tyrosil residues (main and additional maxima at 277 nm and 284 nm, respectively), (Herskovits, 1967).

The results from the SDS-PAGE analyses are summarized in Table 1. Three of the components designated as *a*, *d* and *j* dominated in the protein sample of the 5-day JA-treated plants and were suppressed or fully absent in the other three samples (the two controls and the 15-day JA-treated plants). Similar distinctions were visible for the 15-day JA-treated protein sample whose dominant fractions *c* and *e* were suppressed in the other three samples (the two controls and the 5-day JA-treated plants). On the other hand, the fractions *b* and *f* occurring in the JA-untreated control samples disappeared after JA treatment.

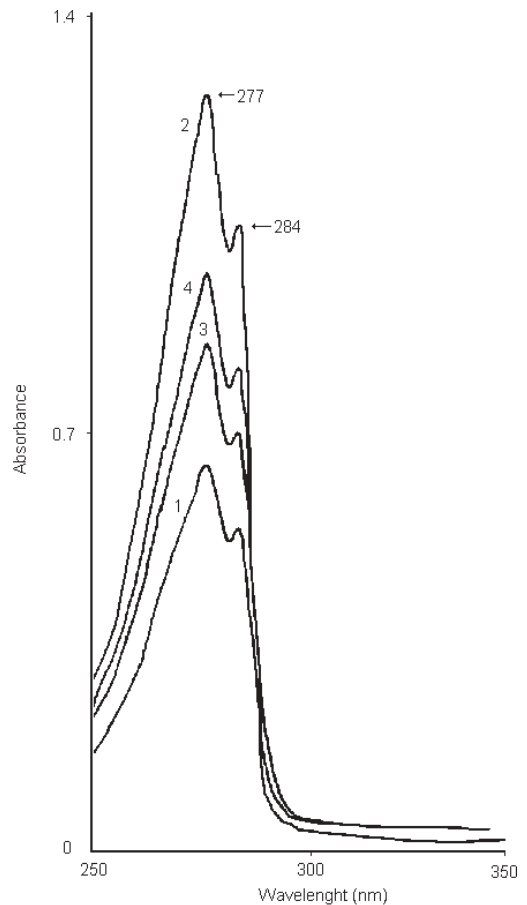

Fig.3. UV-absorption spectra of protein solutions extracted from seeds of *Helianthus annuus* L, harvested as follows: (1) and (2) - on days 5 and 15 after spraying with JA, respectively; (4) and (3) - controls.

Table 1. Molecular weights (M.W.) and relative contents of some protein components resolved by SDS-electrophoresis. M.W. of the protein components were determined using “Pharmacia” low molecular weight calibration kit: 94, 67, 43, 30, 20.1 and 14.4 kDa.

Symbol	M.W. (kDa)	Relative content (%)
<i>a</i>	70.5	11
<i>b</i>	54.8	6
<i>c</i>	49.3	8
<i>d</i>	44.7	6
<i>e</i>	38.4	8
<i>f</i>	12.2	7
<i>j</i>	10.2	21

DISCUSSION

It is known that the level of endogenous JA in plant tissues varies as a function of type of tissues, stage of development and external stimuli. The highest levels were registered in flowers and reproductive tissues (for reviews see Creelman and Mullet, 1995). In the present study, we showed that the level of endogenous JA in developing sunflower seeds is higher during the early stage of seed developing. The maximum value was registered on day 5 after pollination. Furthermore, a significant reduction in JA levels was registered 15 days after pollination. The period studied overlaps the stage of intensive synthesis of seed storage reserves. The exogenous JA affects protein profiles in young seeds. A decrease in the relative protein amount accompanied by the appearance of specific fractions with molecular mass of 70.5, 44.7 and 10.2 kDa were found to occur 5 days 5 days after JA treatment. Wilen et al. (1991) have found that seed storage proteins, napin and cruceferin, could be expressed in *Brassica napus* embryo cultures as a result of JA treatment. The JA responsive polypeptide with molecular mass of 44.7 kDa is very similar to the major jasmonate-inducible polypeptide in *C. pepo* (zucchini) cotyledons with molecular mass of 43.0 kDa (Ananieva and Ananiev, 1999). Further experiments are needed to characterize these JA-responsive polypeptides in sunflower.

In memory of Dr. Anthony A. Donchev whose untimely death was a great loss for our scientific team.

Acknowledgments: The authors thank V. Getov and G. Toromanov from the Institute of Biophysics, BAS, Sofia, for technical assistance in preparing the figures to the manuscript.

References

- Ananiev E.D., G. Abdulova, P. Grozdanov, L. Karagyozov, 2003. Methylation pattern of the intergenic spacer of rRNA genes in excised cotyledons of *Cucurbita pepo* L. (zucchini) after hormone treatment. *Compt. Rend. Acad. Bulg. Sci.*, 56, (6), 111-116.
- Ananieva K.I., E.D. Ananiev, 1999. Effect of methyl ester of jasmonic acid and benzylaminopurine on growth and protein profile of excised cotyledons of *Cucurbita pepo* L. (zucchini). *Biol. Plant.*, 42 (4), 549-557.
- Ananieva K.I., E.D. Ananiev, 2003. Phenylmethylsulphonyl fluoride inhibits the formation of jasmonate-induced proteins in cotyledons of *Cucurbita pepo* (zucchini). *Biol. Plant.*, 46 (3), 357-362.
- Christov, Ch., T. Kovacheva, T. Zafirova, V. Nikolova, 1993. Effect of jasmonic acid on fatty acid composition of sunflower seed oil and yield. *Compt. Rend. Acad. Bulg. Sci.*, 46 (9), 81-84.
- Creelman, R., J. Mullet, 1995. Jasmonic Acid Distribution and Action in Plants: Regulation During Development and Response to Biotic and Abiotic Stress. *Proc. Natl. Acad. Sci. USA*, 92, 4114-4119.
- Darbre, A., J.R. Clamp, 1989. Analytical methods. In: *Practical protein chemistry*, Chapter 8. Ed. A. Darbre, "Mir", Moscow, 300-302 (In Russ.).
- Dathe, W., O. Miersch, J. Schmidt, 1989. Occurrence of jasmonic acid, related compounds and abscisic acid in fertile and sterile fronds of three *Equisetum* species. *Biochem. Physiol. Pflanzen*, 185, 83-92.
- Devoto, A., J. Turner, 2003. Regulation of jasmonate - mediated plant responses in *Arabidopsis*. *Annals of Botany*, 92, 329-337.
- Fling, S.P., D.S. Gregerson, 1986. Peptide and protein molecular weight determination by electrophoresis using a high-molarity Tris buffer system without urea. *Anal. Biochem.*, 155, 83-88.
- Grabner, R., G. Schneider, G. Sembdner, 1976. Gibberelline – XLIII. Mitteilung. Fraktionierung von gibberellinen. Gibberellinkonjugaten und anderen phytohormonen durch DEAE-Sephadex chromatographie. *J. Chromatogr.*, 121, 110-115.
- Herskovits T.T., 1967. Difference spectroscopy. In: *Methods Enzymol.*, Section X., Ed. C.H.W. Hirs, Academic press, New York-London, 11, 748-775.
- Koda, Y. 1992. The role of jasmonic acid and related compounds in the regulation of plant development. *Int. Rev. Cytol.*, 135, 155-199.
- Lopez, R., W. Dathe, C. Bruckner, O. Miersch, G. Sembdner, 1987. Jasmonic acid in different parts of the developing soybean fruit. *Biochem. Physiol. Pflanzen*, 182, 195-201.
- Pandev S., T. Kudrev, V. Stanev, 1981. The influence of separated predominating nutrient elements (N, S, P, K, Ca and Mg) in the nutrient solution on the growth, quantity and quality of sunflower. *Plant Physiol.(Bg)*, 7 (3), 46-51 (In Bulg.).
- Piccioni, R., G. Bellemare, N.-H. Chua, 1982. Methods of polyacrylamide gel electrophoresis in the analysis and preparation of plant polypeptides. In: *Methods in chloroplast molecular biology*, Section N., Eds. M. Edelman, R.B. Hallick, N.-H. Chua, Elsevier, Amsterdam-New York-Oxford, 985-1014.

- Sanders, P., P. Lee, C. Biesgen, J. Boone, T. Beals, E. Weiler, R. Goldberg, 2000. The *Arabidopsis* delayed dehiscence 1 gene encodes an enzyme in the jasmonic acid synthesis pathway. *Plant Cell*, 12, 1041-1061.
- Sembdner, G., B. Parthier, 1993. The biochemistry and the physiological and molecular actions of jasmonates. *Ann. Rev. Plant Physiol. Plant Mol. Biol.*, 44, 569-589.
- Staswick, P., 1994. Storage proteins of vegetative plant tissues. *Annu. Rev. Plant Physiol. Plant Mol. Biol.* 45, 303-322.
- Wasternack, C., B. Hause, 2002. Jasmonates and octadecanoids: signals in plant stress responses and development. *Prog. Nucleic Acids Res. Mol. Biol.* 72, 165-221.
- Wasternack, C., B. Parthier, 1997. Jasmonate-signalled plant gene expression. *Trends Plant Sci.* 2, 302-307.
- Wilens, R., G. van Rooijen, D. Pearce, R. Pharis, L. Holbrook, M. Moloney, 1991. Effects of jasmonic acid on embryo-specific processes in *Brassica* and *Linum* oilseeds. *Plant Physiol.*, 95, 399-405.

EFFECTS OF SHORT-TERM TREATMENT WITH IONIC AND CHELATED COPPER ON MEMBRANE REDOX-ACTIVITY INDUCTION IN ROOTS OF IRON-DEFICIENT CUCUMBER PLANTS

Nadejda Babalakova, Svetlana Boycheva, Snejka Rocheva

Acad.M.Popov Institute of Plant Physiology, Acad. G. Bonchev str., bldg. 21, 1113 Sofia, Bulgaria

Received 12 December 2005

Summary. The effects of different chemical forms of copper – ionic (CuSO_4) and chelated one [Cu(II)HEDTA], applied at micromolar concentrations, on the plasma membrane reductase activity (RA) and proton release in intact roots of cucumber plants grown hydroponically under iron deficiency were studied. Iron starvation provoked high induction of ferric-chelate reductase activity (substrates Fe(III)HEDTA and Fe(III)Citrate) and accelerated cupric-chelate reductase activity (measured with Cu(II)HEDTA and Cu(II)Citrate as electron acceptors), as well as hexacyanoferrate III RA (HCF III). Short-term application of cupric ions in the nutrient solution of iron-deficient plants resulted in a dramatic inhibition of Fe(III)HEDTA RA and Cu(II)Citrate RA and stopped H^+ release by intact roots. The reductase activity of iron-deficient cucumber roots, measured with HCF III, Fe(III)Citrate or Cu(II)HEDTA , however, was inhibited to a lower extent after cupric ions treatment. In addition, cupric-chelate Cu(II)HEDTA , applied at the same concentration in the nutrient solution of iron-deficient ($-\text{Fe}$) cucumber plants maintained the high stimulation of plasma membrane ferric-chelate RA, enhanced proton release by intact roots and produced additional acceleration of cupric-chelate RA and HCF III reduction in the roots. Application of cupric chelate Cu(II)HEDTA improved the iron-deficiency stress responses of cucumber plants.

* Corresponding author, e-mail: nadejda@obzor.bio21.bas.bg

Key words: cucumber (*Cucumis sativus* L.), iron deficiency, ionic and chelated copper treatment, ferric- and cupric-chelate reductase activity, hexacyanoferrate (III) reduction, proton release

Abbreviations: HCF III RA – hexacyanoferrate III reductase activity, Cu(II)Ch – and Fe(III)Ch RA – cupric-chelate and ferric-chelate reductase activity, HEDTA – [N-(2- hydroxyethyl) ethylenediamine triacetate]

INTRODUCTION

Plasma membrane-associated electron-transporting systems (or redox-systems) in plant cells have been involved in many processes directly or indirectly related to cell metabolism and tissue growth: transport of ions and small molecules, plasma membrane H⁺-ATPase stimulation, changes in membrane energization and energy transduction, iron reduction and uptake in dicotyledonous and non-grass monocotyledonous plants, as well as in other processes including defence against pathogens and oxidative stress (Babalaková, 1992; Doering et al., 1998; Babalaková et al., 2003). Trans-plasma membrane redox reactions can participate in the establishment and maintenance of the apoplast redox status related to cell wall loosening and stiffening, thus influencing the interaction of various ionic or chelated compounds in soil or nutrient solutions. Among the plasma membrane reductases, ferric-chelate reductase activity induced by iron deficiency in roots of dicotyledonous plants is the best studied (Robinson et al., 1999; Schmidt, 1999; Moog and Bruggemann, 1994). Under conditions of adequate iron supply, intact roots of many dicotyledonous and monocotyledonous plants can also reduce different cupric-chelates, but their physiological roles and relation to copper uptake by plant roots are not clear, yet (Babalaková and Schmidt, 1996; Holden et al., 1996; Weger, 1999; Babalaková and Traykova, 2001). Resolving the regulation of iron and copper homeostasis in plant cells is extremely important for both plant productivity and human nutrition. Iron deficiency is spread in different crops, mainly in soils with high pH and increased calcium carbonate content (Romera et al., 1997; Wei et al., 1997). In response to iron deficiency, all plants except the grasses develop several biochemical and morphological reactions to ameliorate iron solubilization and uptake from the soil solution (Schmidt, 1999; Hell and Stephan, 2003). The biochemical and physiological mechanisms induced in dicotyledonous plants under conditions of iron deficiency comprise three main processes. The first one includes an increased release of protons through the activation of plasmalemma P-type ATPase proton pump to acidify the surrounding solution, thus enhancing Fe(III)-containing compounds solubility (Wei et al., 1997; Espen et al., 2000). The second process is an obligatory reduction of ferric-chelates by a membrane-associated Fe(III)-chelate reductase to the more soluble ferro-complexes (Chaney et al., 1972; Moog and Bruggemann, 1994; Robinson et al., 1999). The third

adaptive biochemical response is an induction of the synthesis of a specific transporter for ferro-ions in plasmalemma of root cells (Schmidt, 1999; Hell and Stephen, 2003). Besides a high induction of ferric-chelate reductase activity in roots of iron-deficient plants, the reduction capacity for cupric-chelates also rises, but its relation to the uptake of copper and iron is not clear (Babalakova et Schmidt, 1996; Holden et al., 1996; Babalakova and Traykova, 2001; Weger, 1999). It has been established that ionic copper causes an inhibition of both the induction and function of ferric-chelate reductase in roots of iron-deficient plants (Alcantara et al., 1994; Schmidt et al., 1997; Romera et al., 1997). However, no data concerning the influence of chelated copper on the iron-deficiency plant responses are available, offering us the possibility to compare the effects of ionic and chelated copper on the ferric- and cupric-chelate reductases in iron-deficient cucumber roots.

The reactivity of copper ions to form stable complexes and to participate in redox-reactions at the plasma membrane put forward the conception that copper can displace iron from Fe(III) complexes in nutrient solutions with iron supply (Guinn and Joham, 1963; Taylor and Foy, 1995; Laurie et al., 1991). Data describing what might be the plant reaction towards cupric-chelates in the absence of iron are not available. Some controversial data exist about the extent of uptake of ionic or chelated elements. It has previously been shown that accumulation of copper may be markedly affected by the chemical form of the applied copper depending on the charge of Cu-complexes. The comparison of the uptake patterns of positive copper complex with anion Cu-complex demonstrates that Cu(II)-EDTA is accumulated poorly (Coombes et al., 1977, 1978).

Recently, the results of Schmidt et al. (1997) underline that both ionic Cu and Cu(II)EDTA can be readily transported through the plasmalemma of root cells. The uptake of the intact chelate molecule has been reported to occur in chelator-buffering solutions indicated by increased Cu concentrations in plants grown in media with copper and other elements (Taylor and Foy, 1985; Bell et al., 1991; Laurie et al., 1991). The conclusions of some authors suggest that the primary toxic effect of Cu(II)EDTA could be the induction of iron deficiency in plant leaves (Taylor and Foy, 1985). The uptake of either ionic or chelated metals may depend on plant species or cultivar, stability and concentration of the metal complex and solution pH (Laurie et al., 1991).

The existing controversial results regarding copper effects on plant iron nutrition and various older data interpretations, as well as the experiments with high metal concentrations, stimulated us to compare the effects of micromolar concentrations of ionic and chelated copper on the activity of root membrane reductases and proton release in cucumber plants grown under conditions of iron starvation.

MATERIAL AND METHODS

Plant material

Seeds of cucumber (*Cucumis sativus* L. – cultivar Gergana) were germinated in Petri dishes on moistened with 0.1 mM CaCl_2 filter paper, in the dark at 28° C for 3 days. Uniform seedlings were put to grow in an environmental chamber in plastic pots on one-tenth concentration of Hoagland-Arnon I solution. Two days later the plants were divided into plus and minus Fe variants and fed on a half-strength nutrient solution, followed by complete nutrient solution. Nutrient solutions were changed every second day and pH was adjusted at 6.0 with KOH and supplemented with 20 μM Fe(III)-HEDTA (hydroxyethyl ethylenediamine-triacetic acid), prepared as Tris-KOH salt, pH 5.5 (for control, +Fe plants). Fe-deficient cucumber plants were grown on a nutrient solution without Fe.

Short-term treatment of control (+Fe) and Fe-deficient (-Fe) plants with ionic and chelated Cu

The first set of experiments was performed with 10-11-day-old cucumber plants (grown 5 days without Fe) and treated for 24 h with 10 or 20 μM CuSO_4 , or 20 and 100 μM Cu(II)HEDTA. The plants were also treated with 20 μM Fe(III)HEDTA. The same procedure was repeated with 15-16-day-old plants (subjected to Fe-starvation for 10-11 days). The chemical forms of applied copper, used to compare their effects in control (+Fe) and Fe-deficient cucumber plants had different electrical charges. Ionic copper(II) sulfate pentahydrate forms in water solution cupri-hexahydrate cation - $[\text{Cu}^{\text{II}}(\text{OH}_2)_6]^{2+}$. HEDTA forms anion complex with copper sulfate in water solution – hydroxyethyl ethylenediamine-triacetato cuprate – $[\text{Cu}^{\text{II}}\text{HEDTA}]^{2-}$ (Coombes et al., 1978).

Assay of redox-proteins activity. Ferric- and cupric-chelate reductase activity (FeChRA, CuChRA) measurements

Two ferric-complexes - Fe(III)HEDTA and more natural Fe(III)Citrate, prepared as Tris-KOH salt stock solutions, pH 5.5 were used as enzyme substrates (electron acceptors). Cupric-chelate reductase activity was also measured with two copper complexes – Cu(II)HEDTA and Cu(II)Citrate (stock solutions with pH 6.5) to compare the rate of activity of both reductases. Intact cucumber roots reduction capacity was followed in dark vessels, 1 h duration as described previously (Babalaková and Schmidt, 1996, Babalaková and Traykova, 2001). The reductase activity of intact roots was expressed in μmol Fe(II) or Cu(I) / g R FW / h.

Hexacyanoferrate III (HCF III) was also used as impermeable electron acceptor

for evaluation of the activity of standard or constitutive redox-system at the plasma-membrane of root cells. The reductase activity with HCF III was performed according to Schmidt (1994). The reductase activity was expressed in micromoles reduced iron per gram root FW per h.

pH change and proton release measurements

The change in the complete nutrient solution of (+Fe) and (-Fe)-cucumber plants was accompanied with daily pH monitoring in order to follow the expression of iron-deficiency responses as an enhanced proton release in the solution. To compare the effect of ionic and chelated copper on the proton release, several concentrations were used – 0.2 (control), 2 and 20 μM Cu^{2+} or equimolar concentrations of Cu(II)HEDTA . The changes in pH of the nutrient solution were followed in the course of three days.

Statistical analysis

The experiments were repeated at least 3 times with 6 to 8 intact plants in each variant. The data presented are the average of 18 to 24 samples and the values in the tables represented the standard errors of the mean values. The differences between the variants were compared by Student's t-test at 5% level of significance.

RESULTS AND DISCUSSION

Cucumber seedlings grown for 5 days without Fe in the nutrient solution started to develop leaf chlorosis and root morphological changes characteristic for iron deficiency. A marked enhancement of ferric- and cupric-chelate reductase activity (RA), and HCF III RA was also measured (Table 1 – A and B). We compared the reductase activity with two different electron acceptors, using Fe and Cu complexing agents – HEDTA and citrate. Fe-deficient cucumber roots demonstrated higher stimulation of ferric-chelate RA in the presence of Fe(III)HEDTA as an electron acceptor (about 7-fold) as compared with Fe(III)Citrate used as a substrate (about 4-fold increase as compared to the control, +Fe). Another difference included reactions of RA after short-term application of Cu^{2+} . Fe(III)HEDTA RA in iron-deficient cucumber roots was highly inhibited by ionic copper and became even lower than the control (+Fe) activity (Table 1–A and B). The considerable induction of ferric-chelate reductase activity due to iron starvation in cucumber roots disappeared entirely after copper ions treatment. The inhibition of RA in iron-deficient cucumber roots by copper ions with Fe(III)Citrate used as a substrate was lower and compared with the activity of (+Fe) plants some stimulation was registered (Table 1 – B). Iron starvation induced also a strong increase in the cupric-chelate reductase activity (about 7-8-fold), measured with Cu(II)Citrate as an electron acceptor, similar to the stimulation of

Table 1 – A and B. Effect of short-term treatment with ionic copper ($20 \mu\text{M Cu}^{2+}$) on the reduction rate of ferric- and cupric-chelates in intact roots of 10-11-day-old control (+Fe) and iron-deficient (-Fe) cucumber plants.

A	Reduction of Fe(III) - and Cu(II)-chelates ($\mu\text{mol Fe(II) or Cu(I) g}^{-1} \text{FW h}^{-1}$)					
	Fe(III)-HEDTA		Cu(II)-Citrate		HCF III	
	Value	% to + Fe	Value	% to + Fe	Value	% to + Fe
+Fe	0.496 ± 0.035	100	0.217 ± 0.011	100	1.133 ± 0.076	100
-Fe	3.548 ± 0.115	715	1.806 ± 0.095	832	4.670 ± 0.280	412
+Fe + Cu^{2+}	1.010 ± 0.061	204	0.375 ± 0.017	173	1.805 ± 0.093	159
-Fe + Cu^{2+}	0.127 ± 0.007	3.6 (% to -Fe)	0.068 ± 0.004	3.8 (% to -Fe)	1.229 ± 0.067	26.3 (% to -Fe)
		25.6 (% to +Fe)		37.3 (% to +Fe)		108.5 (% to +Fe)
B	Fe(III)-Citrate		Cu(II)-HEDTA			
	Value	% to + Fe	Value	% to + Fe		
+Fe	0.215 ± 0.011	100	0.101 ± 0.005	100		
-Fe	0.905 ± 0.050	421	0.286 ± 0.016	283		
+Fe + Cu^{2+}	0.275 ± 0.014	128	0.175 ± 0.011	173		
-Fe + Cu^{2+}	0.315 ± 0.016	34.8 (% to -Fe)	0.111 ± 0.006	39 (% to -Fe)		
		146.5 (% to +Fe)		110 (% to +Fe)		

Fe(III)HEDTA RA in (-Fe) plants (Table 1 – A). However, lower (only 2-fold) stimulation was observed under conditions of iron deficiency using Cu(II)HEDTA as an electron acceptor for cupric-chelate RA (Table 1- B). A very strong inhibition of Cu(II)Citrate RA in (-Fe) plant roots was registered after 24-h treatment with ionic copper, the extent of inhibition being similar to that of Fe(III)HEDTA reductase activity. In our study, Fe-chelate RA was measured at a pH optimum of 5.5 and Cu-chelate RA optimum was higher at more alkaline pH (6.5). It was supposed for dicotyledonous plants that the reduction of ferric- and cupric-chelates could be performed by one and the same membrane reductase (Welch et al., 1993). Later investigations confirmed the presence of various redox proteins at the plasma membrane that can act as cupric- and ferric-chelate reductases (Babalaková and Schmidt, 1996; Holden et al., 1996; Weger, 1999; Babalaková et al., 2003). The pH optima of the two reductases were also different. Other results suggested that ferric-chelate reduc-

Table 2. Changes in reductase activity using different electron acceptors in the roots of 16-day-old cucumber plants grown under iron deficiency conditions and after short-term application of copper ions (20 μM Cu^{2+} , 24 h).

Variants	Reduction of Fe(III)- and Cu(II)-chelates ($\mu\text{mol Fe(II)}$ or Cu(I) g^{-1} FW h^{-1})					
	Fe(III)-Citrate		Cu(II)-Citrate		HCF(III)	
	Value	% to + Fe	Value	% to + Fe	Value	% to + Fe
+Fe	0.170 \pm 0.082	100	0.150 \pm 0.07	100	0.950 \pm 0.06	100
-Fe	0.750 \pm 0.055	441	1.312 \pm 0.11	875	4.338 \pm 0.35	457
+Fe + Cu^{2+}	0.205 \pm 0.012	121	0.230 \pm 0.03	153	1.236 \pm 0.07	130
-Fe + Cu^{2+}	0.243 \pm 0.016	32.4 (% to -Fe)	0.064 \pm 0.01	4.9 (% to -Fe)	0.893 \pm 0.06	20.6 (% to -Fe)
		143 % to + Fe		43 % to + Fe		94 % to + Fe

tase activity in Fe-deficient plants (“turbo” reductase) measured at pH 5.5 might be different from the constitutive redox-proteins (Holden et al., 1996; Susin et al., 1996; Babalaková and Schmidt, 1996). High activation of cupric-reductase in the roots of Fe-deficient plants might be connected with an increased copper uptake to the same extent under iron starvation (Herbic et al., 1996). The direct connection between enhanced cupric-chelate reduction and increased copper content in plant roots, however, is not clear (Babalaková and Traykova, 2001).

Older cucumber plants, grown for 10-11 days without Fe kept the high stimulation of FeChRA, CuChRa and HCR III RA under conditions of iron starvation (Table 2). Hexacyanoferrate III (FeCN) reductase activity as an expression of a constitutive redox-system at the plasma membrane was as high as Fe(III)Citrate RA (Table 1-A, Table 2) under conditions of iron deficiency. Treatment with copper ions showed the same reactions of iron-deficient reductases in roots as in younger plants. The induction of both Fe-chelate RA and HCF III RA under iron starvation in different plants varied to a different extent due to enzyme heterogeneity (Schmidt, 1994; Lynnes et al., 1998). The considerable inhibitory effect of ionic copper on plant root reducing capacity upon Fe deficiency confirmed previously obtained results (Alcantara et al., 1994; Romera et al., 1997; Schmidt et al., 1997). The addition of the same micromolar concentrations cupric chelate in the nutrient solutions of iron-sufficient and iron-deficient plants demonstrated different reactions of plant reductases. The effects of short-term treatment of control and iron-deficient cucumber plants with equimolar concentrations of ionic and chelated copper on Fe(III)-HEDTA RA and HCF III RA are presented in Tables 3 and 4. Application of Cu(II)HEDTA produced some additional increase of ferric-chelate reductase activity in both control (+Fe) and iron-

Table 3. Effects of ionic copper or chelated Cu and Fe on the Fe(III) HEDTA reductase activity in cucumber plants grown under conditions with normal iron supply or iron deficiency.

24 h Variants treatment with ionic and chelated Cu or Fe	Fe(III)-HEDTA Reductase Activity ($\mu\text{mol Fe(II) g}^{-1} \text{FW h}^{-1}$)				
	+ Fe	% to + Fe	- Fe	% to - Fe	% - Fe / +Fe
Control	0.436 \pm 0.071	100	3.67 \pm 0.211	100	842
+20 $\mu\text{M Cu}^{2+}$	0.854 \pm 0.065	196	0.13 \pm 0.011	3.5	15
+20 $\mu\text{M Cu(II)-HEDTA}$	0.580 \pm 0.031	133	4.49 \pm 0.322	122	774
+20 $\mu\text{M Fe(III)-HEDTA}$	0.685 \pm 0.032	157	3.92 \pm 0.285	107	572

Table 4. Alteration of HCF III reductase activity in roots of cucumber plants after treatment with ionic or chelated Cu and Fe in control (+Fe) and iron-deficient (-Fe) cucumber plants.

24 h Variants treatment with ionic and chelated Cu or Fe	HCF III Reductase Activity ($\mu\text{mol Fe(II) g}^{-1} \text{FW h}^{-1}$)				
	+ Fe	% to + Fe	- Fe	% to - Fe	% - Fe / +Fe
Control	1.10 \pm 0.065	100	4.84 \pm 0.355	100	440
+20 $\mu\text{M Cu}^{2+}$	1.55 \pm 0.091	141	1.23 \pm 0.081	25	79
+20 $\mu\text{M Cu(II)-HEDTA}$	1.32 \pm 0.084	120	7.13 \pm 0.376	147	540
+20 $\mu\text{M Fe(III)-HEDTA}$	1.34 \pm 0.092	122	4.92 \pm 0.343	102	367

deficient (-Fe) plants (Table 3). Thus, treatment with cupric chelates can keep the physiological response of iron deficient plants to develop very high reductase activity. A similar stimulation of HCF III RA was observed after Cu-chelate treatment (Table 4 – 5-fold increase of RA). To follow the induction of reductase activity in Fe-deficient cucumber plants we carried out treatment with Fe(III)HEDTA as a source of iron nutrition also (Tables 3 and 4). Ferric-chelate application for 24 h did not cause any decline of RA in iron-deficient cucumber roots, thus indicating that initial adaptation of cucumber plants after iron re-supply with ferric-chelate needed more than one day. We tested also the effect of a higher concentration of cupric chelate (100 micromoles) on the RA (Table 5). Cupric chelate application stimulated the Fe(III)HEDTA RA and HCF III RA in both control and iron-deficient plants. The alteration of RA in Fe-deficient plants was related to pH changes in the nutrient solutions during iron starvation and copper treatment. Application of ionic copper (Cu^{2+}) inhibited the release of protons by the roots of Fe-deficient plants (Fig. 1 – data with 2 and 20 $\mu\text{M Cu}^{2+}$) which was in correlation with the high inhibition of Fe-chelate RA by ionic copper. At the same time chelated copper application stimulated the H^+ extrusion by the roots of Fe-deficient cucumber plants and thus the pH of the

Table 5. Influence of short-term (24-h) application of cupric chelate in the nutrient solution on the ferric-chelate and hexacyanoferrate III reductase activities in the root plasma membrane of control (+Fe) and iron-deficient (-Fe) 15-day-old cucumber plants.

Variants	Reduction of Fe(III) - chelates ($\mu\text{mol Fe(II) g}^{-1} \text{FW h}^{-1}$)			
	Fe(III)-HEDTA RA		HCF(III) RA	
	Value	% to + Fe	Value	% to + Fe
+Fe	0.340 ± 0.051	100	0.916 ± 0.048	100
-Fe	3.138 ± 0.154	923	4.788 ± 0.227	523
+Fe + 20 μM Cu(II) HEDTA	0.446 ± 0.032	131	1.079 ± 0.062	118
+Fe + 100 μM Cu(II) HEDTA	0.548 ± 0.035	161	0.989 ± 0.055	98
-Fe + 20 μM Cu(II) HEDTA	4.490 ± 0.283	143 (% to -Fe)	7.132 ± 0.357	149 (% to -Fe)
-Fe + 100 μM Cu(II) HEDTA	4.053 ± 0.294	129 (% to -Fe)	6.500 ± 0.323	136 (% to -Fe)

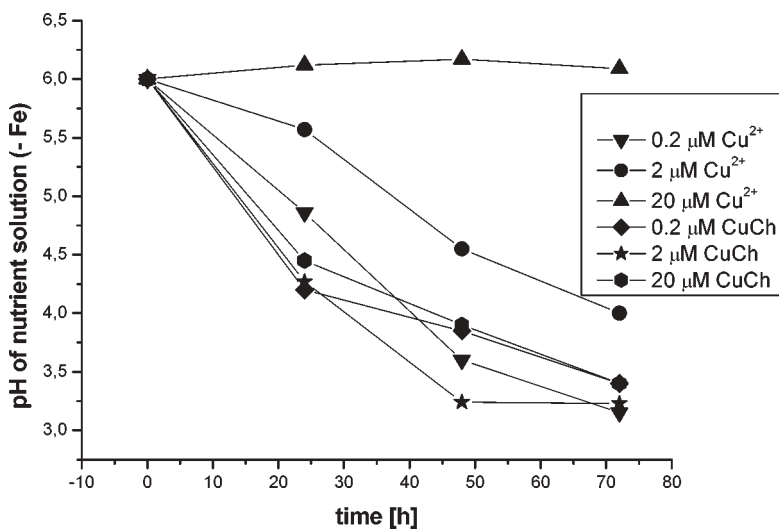

Fig. 1. pH alterations of the nutrient solution (initial pH 6.0) of iron-deficient (-Fe) cucumber plants grown in the presence of cupric ions or Cu-chelates [Cu(II)HEDTA] applied at micromolar concentrations.

nutrient solution of (-Fe) plants decreased from 6.0 to 4.2 - 4.3 after 24 h (Fig.1 – data with 2 μM Cu(II)HEDTA and 20 μM Cu(II)HEDTA). Enhanced acidification of the medium during iron starvation is important for the induction and sustaining of the high level of ferric chelate RA in many plants because the enzyme is pH sensitive (Wei et al., 1997; Schmidt, 1999). It has recently been proved that high apoplastic pH depressed Fe-chelate RA and restricted the uptake of Fe(II) into the cytosol (Kosegarten et al., 2004). The applied concentrations of ionic and chelated copper had an insignificant effect on pH changes of the control (+Fe) solutions (data not shown). Our results showed a correlation between the proton release and the stimulation of ferric-chelate reductase activity under conditions of iron starvation. It has been suggested that the rate of cupric reduction is a function of the free Cu^{2+} as the actual substrate of cupric reductase activity (Holden et al., 1996; Weger, 1999). Our results showed that cupric-chelate reductase at the plasma membrane of Fe-deficient cucumber roots demonstrated a higher activity in the presence of chelated copper. One possible explanation for the inhibitory effect of ionic copper on FeCh RA in iron-deficient roots is based on our assumption that Cu^{2+} might act as a powerful scavenger of the superoxide radical, facilitating Fe-chelate reduction at the plasma membrane (Cakmak et al., 1987; Macri et al., 1992). This suggestion is supported by the experiments with *in vitro* application of copper ions that produced the inhibition of Fe(III)EDTA RA in (-Fe) plants already within the first minutes (Schmidt et al., 1997). Another effect of ionic copper inhibiting to a higher extent the proton release in (-Fe) cucumber plants, might be the reduced activity of the plasmalemma proton pump (Babalakova and Hager, 1994).

Ionic copper can also affect Fe nutrition by the inhibition of some components or subunits of the trans-plasma membrane electron transport chain. In the presence of chelating agents copper ions form chelates that can be uptaken by plant roots (Schmidt et al., 1997). These authors showed that at equimolar Fe and Cu levels, i.e. in the presence of Cu chelates, an induction of the iron-stress response was not inhibited, thus supporting our results for stimulation effects of cupric chelates on the FeChRA in Fe-deficient cucumber plants. The exact site of the copper action remains to be established. In spite of the intensive research, the role of chelation itself and metal complexing agents with different charges in the mechanisms of metal uptake by plants and their action on membrane level with the induction of reductase activity are not yet properly understood. Our results pointed out different levels of ferric- and cupric-chelate reductase activity with different ligands during iron starvation of cucumber plants. Ferric-citrate is known to be the more natural substrate, but the most common chelating agent used to enhance the water solubility of iron in hydroponics, is EDTA or a related substance, such as HEDTA. The high increase in the standard redox-system activity (HCF III RA) in Fe-deficient cucumber roots upon application of cupric chelates suggested strong enhancement of trans-membrane electron transport that might be connected with the sustained activity of the proton pump. Interactions

between the H^+ -ATPase activity and the redox state of the cytoplasm have been suggested to play an important role in the regulation of electron transport by the standard redox system (Schmidt, 1999). Increased activity of standard reductase in iron-deficient plant roots in the presence of cupric chelates might be connected with its probable role for root morphology improvement under conditions of iron starvation (data not shown). Further research is needed to clarify the action of ionic and chelated copper at the membrane level in control and iron-deficient cucumber plants.

CONCLUSION

In the present study, we demonstrated that micromolar concentrations of cupric-chelate Cu(II)HEDTA, applied in the nutrient solution of iron-deficient cucumber plants maintained the stimulation of plasma membrane ferric-chelate reductase activity, as well as accelerated hexacyanoferrate III RA, and cupric-chelate reduction by intact plant roots. In addition, application of cupric chelate improved other stress responses under conditions of Fe-starvation, such as root morphology changes and enhanced proton release in the nutrient solution. These markedly expressed positive effects of cupric chelates were in contrast to the strong inhibitory action of copper ions applied at the same concentrations in the nutrient solutions of iron-deficient plants.

Acknowledgements: Part of this study was supported by the National Science Fund of the Ministry of Education and Science, Sofia (project B – 1406/2004).

References

- Alcantara, E., F. J. Romera, M. Canete, M. D. de la Guardia, 1994. Effect of heavy metals on both induction and function of root Fe(III) reductase in Fe-deficient cucumber (*Cucumis sativus* L) plants. *J. Exptl. Botany*, 45, (281), 1893-1898.
- Babalakova, N. K., 1992. Redox-systems at plasmalemma of plant cells. *Physiologija na rastenijata* 18, (2), 66-83. (Bulgarian J of Plant Physiology).
- Babalakova, N. K., A. Hager, 1994. In vivo and in vitro action of Cu^{2+} and Ca^{2+} on the proton-transporting activities of maize root membrane vesicles. *Comp. Rend. Acad. bulg. Sci.*, 47, (10), 85-89.
- Babalakova, N. K., W. Schmidt, 1996. Cupric-chelate reduction by intact plant roots as an expression of constitutive and inducible redox-systems. *Comp. Rend. Acad. bulg. Sci.* 49, (3), 87-90.
- Babalakova, N., Z. Salama, S. Rocheva, M. El-Fouly, 2003. Divalent cations effect on plasma membrane-bound standard redox-system activity of maize and chick-pea roots. *Compt. rend. Acad. bulg. Sci.* 56, (6), 93-98.
- Babalakova, N., D. Traykova, 2001. Copper-induced cupric- and ferric-chelate reduction by intact barley roots. *Bulg. J. Plant Physiol.*, 27, (3-4), 93-103.

- Bell, P. F., R. L. Chaney, J. S. Angle, 1991. Determination of the copper (II) activity required by maize using chelator-buffered nutrient solutions. *Soil Sci. Soc. American J.*, 55, 1366-1374.
- Cakmak I., D. A. M. van de Wetering, H. Marschner, H. F. Bienfait, 1987. Involvement of superoxide radical in extracellular ferric reduction by iron-deficient bean roots. *Plant Physiol.*, 85, 310-314.
- Chaney, R. L., J. C. Brown, L. O. Tiffin, 1972. Obligatory reduction of ferric chelates in iron uptake by soybeans. *Plant Physiol.*, 50, 208-213.
- Coombes, A. J., N. W. Lepp, D. A. Phipps, 1978. Desorption of copper from excised roots of barley (*Hordeum vulgare* L. C. V. Zephyr), as related to chemical of the applied copper. *Z. Pflanzenphysiol. Bd.*, 87, 279-283.
- Coombes, A. J., D. A. Phipps, N. W. Lepp, 1977. Uptake patterns of free and complexed copper ions in excised roots of barley (*Hordeum vulgare* L. C. V. Zephyr). *Z. Pflanzenphysiol. Bd.*, 82, 435-439.
- Doering, O., S. Luethje, M. Boettger, 1998. To be or not to be – a question of plasma membrane redox? *Progress in Botany*, 59, 328-354.
- Espen, L., M. Dell'Orto, P. De Nisi, G. Zocchi, 2000. Metabolic responses in cucumber (*Cucumis sativus* L.) roots under Fe-deficiency: a ³¹P-nuclear magnetic resonance in-vivo study. *Planta*, 210, 985-992.
- Guinn, G., H. E. Joham, 1963. Displacement of iron from ferric ethylenediamine tetraacetic acid and ferric hydroxyethylenediamine-triacetic acid by copper and zinc. *Soil Science*, 95, 101-104.
- Hell, R., U. W. Stephan, 2003. Iron uptake and homeostasis in plants. *Planta*, 216, 541-551.
- Herbik, A., A. Giritch, C. Horstmann, R. Becker, H. J. Balzer, H. Baeumlein, U. W. Stephan, 1996. Iron and copper nutrition-dependent changes in protein expression in a tomato wild type and the nicotianamine-free mutant chloronerva. *Plant Physiol.*, 111, 533-540.
- Holden, M. J., T. J. Crimmins, R. L. Chaney, 1995. Cu²⁺ reduction by tomato root plasma membrane vesicles. *Plant Physiol.*, 108, 1093-1098.
- Kosegarten, H., B. Hoffmann, E. Roco, F. Grolig, K. H. Gluesenkamp, K. Mengel, 2004. Apoplastic pH and Fe(III) reduction in young sunflower (*Helianthus annuus*) roots. *Physiol. Plant.*, 122, 95-106.
- Laurie, S. H., N. P. Tancock, S. P. McGrath, J. R. Sanders, 1991. Influence of complexation on the uptake by plants of iron, manganese, copper and zinc. I. Effects of EDTA in a multi-metal and computer simulation study. *J. Exptl. Bot.*, 42, 509-513.
- Lynnes, J. A, T. L. M. Derzaph, H. G. Weger, 1998. Iron limitation results in induction of ferricyanide reductase and ferric chelate reductase activities in *Chlamydomonas reinhardtii*. *Planta*, 204, 360-365.
- Macri, F., E. Braidot, E. Petrusa, M. Zancani, A. Vianello, 1992. Ferric ion and oxygen reduction at the surface of protoplasts and cells of *Acer pseudoplatanus*. *Bot. Acta*, 105, 97-103.
- Moog, P. R., W. Brueggemann, 1994. Iron reductase systems on the plant plasma membrane – a review. *Plant Soil*, 165, 241-260.
- Robinson, N. J., C. M. Proctor, E. L. Connolly, M. L. Guerinot, 1999. A ferric-chelate reductase for iron uptake from soils. *Nature*, 397, 694-697.

- Romera, F. J., E. Alcantara, M. D. de la Guardia, 1997. Influence of bicarbonate and metal ions on the development of root Fe(III) reducing capacity by Fe-deficient cucumber plants. *Physiol. Plantarum*, 101, 143-148.
- Schmidt, W., 1994. Reduction of extracytoplasmic acceptors by roots of *Plantago lanceolata* L. Evidence for enzyme heterogeneity. *Plant Sci.*, 100, 139-146.
- Schmidt, W., M. Bartels, J. Tittel, C. Fuhner, 1997. Physiological effects of copper on iron acquisition processes in *Plantago*. *New Phytol.*, 135, 659-666.
- Schmidt, W., 1999. Mechanisms and regulation of reduction-based iron uptake in plants. *New Phytol.*, 141, 1-26.
- Susin, S., A. Abadia, J. A. Gonzales-Reyes, J. J. Lucena, J. Abadia, 1996. The pH requirement for in vivo of the iron-deficiency-induced "turbo" ferric-chelate reductase. *Plant Physiol.*, 110, 111-123, 1996.
- Taylor, G. J., C. D. Foy, 1985. Differential uptake and toxicity of ionic and chelated copper in *Triticum aestivum*. *Canadian J. Botany*, 63, 1271-1275.
- Weger, H. G., 1999. Ferric and cupric reductase activities in the green alga *Chlamydomonas reinhardtii*: experiments using iron-limited chemostats. *Planta*, 207, 377-384.
- Wei, L. C., R. H. Loeppert, W. R. Ocumpaugh, 1997. Fe-deficiency stress response in Fe-deficiency resistant and susceptible subterranean clover: importance of induced H⁺ release. *J. of Experim Bot.*, 48, 239-246.
- Welch, R. M., W. A. Norvell, S. C. Schaefer, J. E. Shaff, L.V. Kochian, 1993. Induction of iron(III) and copper(II) reduction in pea (*Pisum sativum* L.) roots by Fe and Cu status : Does the root-cell plasmalemma Fe(III)-chelate reductase perform a general role in regulating cation uptake? *Planta*, 190, 555-561.

A CASE STUDY OF TENDRAL WINTER MELONS (*CUCUMIS MELO* L.) POSTHARVEST SENESCENCE

Bárbara Albuquerque^{1,2,*}, Fernando C. Lidon¹, Maria G. Barreiro²

¹ Unidade de Biotecnologia Ambiental, Faculdade de Ciências e Tecnologia da Universidade Nova de Lisboa, Quinta da Torre, 2829-516 Caparica, Portugal

² Departamento de Fisiologia Vegetal da Estação Agronómica Nacional, Quinta do Marquês, 2780 Oeiras, Portugal

Received 10 November 2005

Summary. Tendral type cultivar melons (*Cucumis melo* L., *inodorus* group, *Winter melon* variety) were stored for a 75-d postharvest period in a ventilated chamber at 10 °C ± 1 °C and 75% ± 5 % RH. Qualitative degradation of the fruit was observed mainly involving proteins and ascorbic acid. It was also found that the sugar/acid ratio increased while the glucose/fructose ratio decreased, thus making the fruit sweeter. Sucrose was the predominant sugar found and glucose was the major reducing sugar. Citric acid was the major component of the organic acid fraction of the *Tendral* mesocarp. The ACC oxidase activity declined as the fruit became overripe. Membrane degradation linked to the accumulation of hydroperoxides was modulated by a progressive failure of the antioxidant enzymes system. A reduction in superoxide dismutase activity as well as in catalase activity was observed. It can be concluded that the oxidative status of *Tendral* melons during postharvest storage increased progressively.

Keywords: fruit quality, oxidative stress, postharvest storage, winter melon

Abbreviations: ACC – 1-aminocyclopropane-1-carboxylic acid, CAT – catalase, H₂O₂ -hydrogen peroxide, HPLC – high performance liquid chromatography, RH – relative humidity, SOD - superoxide dismutase, SSC – soluble solids content

* Corresponding author, e-mail: baba_albuquerque@hotmail.com

INTRODUCTION

Melon (*Cucumis melo* L.) is a commercially important crop in many countries, being cultivated in all temperate regions of the world, in part due to its good adaptation to soil and climate (Villanueva et al., 2004). According to FAO, in 2002 this fruit production in Europe was higher than 3 million tons, with a 25 % increase for the last 10 years.

Inodorus group melons include, among other varieties, *Honeydew*, *Crenshaw*, *Casaba* and *Winter melon*. They have smooth rinds and do not have a musky odor. Previous studies with this group melons showed that its normal shelf life is about 14 days (Ryall and Lipton, 1979). When melons are stored under cool (10 °C range) and high-humidity (80 - 90 %) conditions, they could be preserved for about 3 weeks (Hardenburg et al., 1986).

Tendral type cultivars (*Winter melon* variety, *Inodorus* group) are with dark skin and greenish flesh (Pardo et al., 2000) and can be stored relatively longer, allowing an extension of the commercialisation period practically until Christmas and ensuring that it attains the highest market value (Pintado et al., 2003).

Camara et al. (1995) defined quality as a set of internal and external characteristics that can be appreciated by human senses. In the particular case of melon, sensory evaluation criteria should be complemented with instrumentally determined parameters, such as pH, soluble solids content (SSC), firmness and both external and internal color, for the proper characterization of the product (Pardo, 2000).

In higher plants, senescence is characterized by the breakdown of cell wall components. Membrane disruption leads to cellular decompartmentation and loss of tissue structure (Paliyath and Droillard, 1992). Free radicals derived from oxygen are largely involved in the senescence processes, particularly in membrane deterioration (Droillard et al., 1987). They induce the peroxidation of membrane lipids, thus resulting in a loss of membrane integrity and membrane-bound enzyme activities (Bartoli et al., 1996).

This work aimed to investigate the changes in fruit quality during a 75-days postharvest period, by analysing intrinsic parameters coupled to the oxidative stress triggered during storage.

MATERIALS AND METHODS

Plant material, external characteristics and storage conditions

In 2003, *Tendral* melons (*Cucumis melo* L. *Inodorus* group) were grown outdoors using commercial growing conditions in Elvas (Portugal). Seeds used were maintained in the Estação Agronómica Nacional, Oeiras, Portugal. Fruits were collected

in late August. They weighed 2.31 ± 0.09 kg, and had a diameter, height and volume of 14.7 ± 0.2 cm, 20.5 ± 0.5 cm and 2.242 ± 0.156 dm³, respectively. They were stored in a ventilated room ($10 \text{ }^\circ\text{C} \pm 1 \text{ }^\circ\text{C}$ and $70 \pm 5 \%$ RH) for 75 days.

Physicochemical analysis

The analyses of flesh firmness, pulp colour, total SSC and titratable acidity were carried out according to Barreiro et al. (2001). They were carried out 20, 40, 60 and 75 days after harvest. The measurements were done in three replicates of five fruits each.

Flesh firmness: Flesh firmness was estimated in the equatorial hipodermal mesocarp tissue, using a Bellevue penetrometer, by the resistance of the flesh to the penetration of a standard plunger (1 cm long x 8 mm diameter) and expressed as a mean force in Newtons.

Pulp colour: The hipodermal mesocarp tissue colour was measured using a Minolta CR-300 colorimeter to provide a specific colour value based on the amount of light transmitted through the commodity. Colour values were expressed on the CIE Colour System with the L*C*H° axis representing lightness, chrome and hue angle, respectively.

Total SSC: A hand refractometer Atago ATC-1 was used for measuring total SSC in extracted juice, at 20 °C. The refractometer measures the refractive index, which indicates how much a light beam will be slowed down when it passes through the fruit juice.

Titrable acidity: Titratable acidity was determined by titrating 10 ml of fruit juice with 0.1 N NaOH, to an end point of pH 8.2, as indicated by a pH meter CD 7000 WPA. The volume of NaOH needed was used to calculate the titratable acidity, using a multiplication factor of 0.64 (since citric acid is the major acid presented).

Physiological analyses

Protein content: Protein content was measured as described by Lowry et al. (1951), with minor modifications, to minimize the absorbance of interfering substances (Lidon, 1994). After addition of 5 ml of Lowry C reagent and 500 µl of Folin reagent to 500 µl of diluted melon juice (1 g of fruit mesocarp flesh homogenized with 10 ml distilled water), samples were maintained at 25 °C for 30 min. The absorbance was determined at 540 nm, using three replicates of five fruits on days 20, 40, 60 and 75 after harvest.

Electrolyte leakage: Electrolyte leakage was measured using the method of Gemma et al. (1994), with few modifications, 20, 40, 60 and 75 days after harvest. Three replicates of five fruit discs mesocarp tissue (8 mm in diameter) were incubated in a beaker with 10 ml distilled water for 3 h with slight agitation at 25 °C.

Conductivity of solution was measured using a GLP31 (Crison) dip cell and a conductivity bridge. Samples were submitted to 90 °C for 1 h, and electrolyte leakage was measured again to determine total electrolyte leakage.

Acyl lipids peroxidation: Acyl lipids peroxidation was based on the thiobarbituric acid (TBA) test (Böhme and Cramer, 1971), using three replicates from five fresh fruit discs of mesocarp tissue 20 and 60 days after harvest. This test, which measures malonaldehyde as an end product of lipid peroxidation, was performed using 0.1 % of trichloroacetic acid (TCA) solution. Homogenates were centrifuged at 15000 x g for 10 min and 0.5 ml of the supernatant obtained was added to 1.5 ml 0.5 % TBA in 20 % TCA. The mixture was incubated at 90 °C in a shaking water bath, and the reaction was terminated by placing the reaction tubes in an ice-water bath. The samples were centrifuged at 10000 x g for 5 min and the absorbance of the supernatant was read at 532 nm. The absorbance was determined at both 440 and 600 nm to minimize the interference of carbon skeletons. A coefficient of 155 mM cm⁻¹ was used.

Sugar quantification: Sugar extraction was carried out on 20, 60, 75 days after harvest following the method of Hudina and Stampar (2000). Sample of 20 g of 10 fruit fresh mesocarp flesh were dissolved in 100 ml distilled water and centrifuged at 15000 x g for 15 min at 4 °C. Filtration was carried out through Whatman No 4 and Millipore 0.45 µm filters. Sugars were identified and quantified by HPLC using a Waters R401 refractive index detector and a Sugar-Pack (Waters) column kept at 90 °C. A flow rate of 0.5 ml min⁻¹ was applied to an aqueous mobile phase of EDTA-Ca (50 µL L⁻¹). An aliquot of 20 µl was injected. Each sample was analyzed in three replicates.

Acid quantification: Acid extraction was similar to that of sugars, but thereafter, for the isolation and characterization, a Beckman Gold 168 diode-array detector together with an Aminex HPX 87H (BioRad) column were used. A flow rate of 0.5 ml min⁻¹ was applied at room temperature to a mobile phase of 5 mM H₂SO₄. An aliquot of 20 µl was injected. Each sample was analyzed in three replicates.

Ascorbic acid quantification: The concentration of ascorbic acid was determined 20, 60 and 75 days after harvest as previously described (Romero-Rodrigues et al., 1992). A sample of 20 g mesocarp flesh from 10 fruits were homogenized with 30 ml of 6 % metaphosphoric acid and then centrifuged at 15000 x g for 25 min at 4 °C. Filtration was carried out twice through Whatman No 4 filter paper. Volume was brought to 100 ml with 6 % metaphosphoric acid and samples were again filtered through Millipore 0.45 µm filters. Ascorbic acid was quantified using HPLC with a Waters 440 detector and a Spherisorb ODS2 5 µm (Waters) column. A flow rate of 0.4 ml min⁻¹ was applied at room temperature to a mobile phase of H₂SO₄ (pH 2.3). An aliquot of 20 µl was injected. Each sample was analyzed in three replicates.

Enzyme assays

In the assay conditions for measuring enzymes activities, the applied substrate was saturated in order to obtain maximum apparent activities.

Enzymes implicated in the control of the oxidative stress: These enzyme activities were determined 20 and 60 days after harvest using fresh mesocarp tissue discs. The analyses were done in triplicate with five fruits each. Superoxide dismutase activity was determined following the method of McCord and Fridovich (1969). Catalase activity was measured according to Patra et al. (1978). The analyses of ascorbate peroxidase followed the method of Nakasano and Asada (1981) whereas dehydroascorbate reductase and glutathione reductase activities were measured following the procedure of Dalton et al. (1986).

ACC oxidase extraction and quantification: ACC oxidase extraction was performed using a modified method of Dong et al. (1992). Samples of 100 g from 10 fruits mesocarp flesh were homogenized with 150 ml of 400 mM potassium phosphate buffer (pH 7.2) containing 10 mM sodium bisulphite, 3 mM sodium ascorbate, 5 mM dithiothreitol (DTT) and 4 mM 2-mercaptoethanol. The homogenate was squeezed through 4 layers of cheesecloth, centrifuged at 15000 x g for 40 min at 4°C and the supernatant discarded. The pellet was resuspended in 20 ml 25 mM HEPES (pH 7.2) containing 1 mM DTT, 3 mM sodium ascorbate and 30% glycerol (v/v) and stirred for 15 min. Triton X-100 (0.8 %) was added and the mixture, stirred for 15 min and centrifuged at 15000 x g for 30 min at 4°C. The supernatant was assayed. Sample analysis was carried out according to Vioque and Castellano (1994). A volume of 0.9 ml of a standard reaction mixture (100 mM HEPES (pH 6.7), 1 mM ACC, 0.2 mM FeSO₄, 10 mM sodium ascorbate, 16 % CO₂ in the gas phase) was added to 0.1 ml of enzyme solution. Incubation was carried out at 30 °C for 30 min, in sealed 10 ml vials. The production of ethylene was determined by gas chromatography, using a Gas Chromatographs Pye Unicam Series 204, with a Porapak Q column and a flame ionization detector. A nitrogen flow rate of 30 ml min⁻¹ was used as a gas carrier. In the oven, temperature was set to 100 °C, the injection port was kept at room temperature, the detector being maintained at 150 °C. Three replicates of each sample were injected. Ethylene was identified and quantified by comparison with a peak area of a standard ethylene gas sample (29 µL L⁻¹), 20, 60 and 75 days after harvest.

Quality parameters

Sensorial quality was determined at individual stations by a 10-member preference panel. Each station displayed melon cubes of middle mesocarp tissue taken from the equatorial region of the fruit. The panellists judged the external appearance, texture and flavour of melons. A continuous scale of 5 was used for each parameter (1- Bad;

3 – Acceptable; 5 – Very Good). Global consumer acceptance was determined by the sum of external appearance, texture and flavour (multiplied by a 3, 7 and 10 factor, respectively).

Statistical analysis

Statistical analysis of data was performed using one-way analysis of variance (ANOVA) ($P < 0.05$) applied to the studied parameters. Based on the ANOVA results, a Tukey's test was performed for mean comparison, for a 95 % confidence level. Different letters indicate significant differences in a multiple range analysis for 95 % confidence level.

RESULTS AND DISCUSSION

The effect of storage on flesh colour (Table 1) affected mainly the hue angle which implicated the development of the yellow colour in fruit. Even though there was no change in fruit colour (a negative correlation factor of 96.2% between C^* and H° was found). In contrast, total SSC, although displaying slight fluctuations, remained stable, as previously documented by other authors (Ogle and Christopher, 1957; Dumas de Vaultx and Aubert, 1976; Evensen, 1983). Fruit juice pH increased during the 75 days of storage (Fig. 1) leading to a decrease of titrable acidity (c. a. 44 %), due to organic acids degradation and consumption. These data further supported the finding of Barreiro et al. (2001). The initial pH of the juice correlated closely during the postharvest period in 89 %, whereas that of titrable acidity reached c.a. 93.5 %. In

Table 1. Physicochemical characterization of *Tendral* melon fruit during the postharvest storage period. Each value is the mean of three replicates of five fruits each \pm standard error. Different letters indicate significant differences in a multiple range analysis for 95 % confidence level, on the basis of Tukey's test.

Days after harvest	Colour	Firmness (N)	SSC (%)
20	L 68.469 \pm 1.310 (a)	15.63 \pm 1.08 (a)	10.01 \pm 0.61 (a)
	C 15.508 \pm 0.436 (a)		
	H° 107.754 \pm 0.477 (a)		
40	L 68.499 \pm 1.012 (a)	16.99 \pm 0.80 (b)	9.43 \pm 0.44 (a)
	C 15.477 \pm 0.416 (a)		
	H° 106.784 \pm 0.621 (ab)		
60	L 67.852 \pm 1.433 (b)	16.48 \pm 0.48 (ab)	10.56 \pm 0.47 (a)
	C 17.451 \pm 0.672 (a)		
	H° 103.129 \pm 0.690 (c)		
75	L 63.001 \pm 2.090 (b)	19.25 \pm 0.77 (b)	9.63 \pm 0.67 (a)
	C 16.486 \pm 0.743 (a)		
	H° 104.353 \pm 0.851 (bc)		

addition, both parameters displayed a correlation of 90.2 % which indicates the occurrence of similar patterns for the quantification of free and conjugated acids.

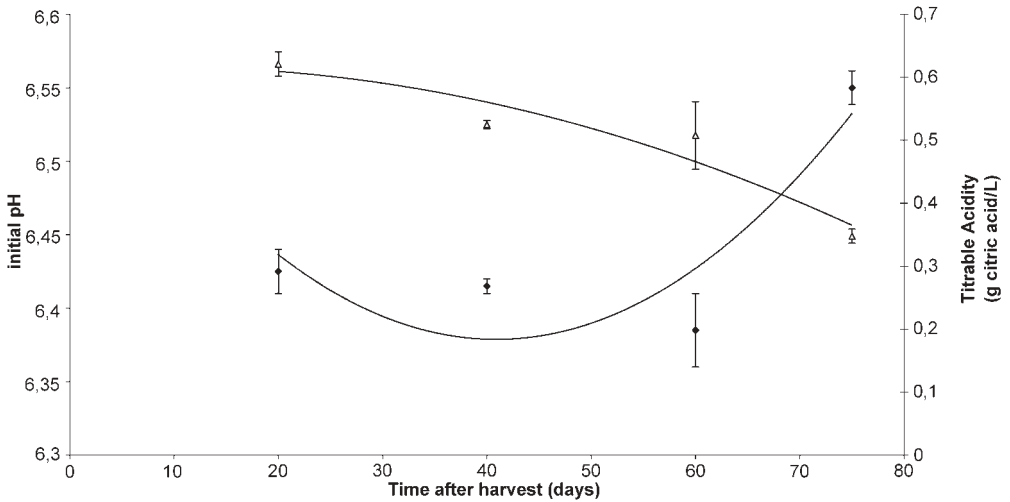

Fig. 1. Initial fruit juice pH (♦) ($r^2 = 0.910$) and titrable acidity (Δ) ($r^2 = 0.997$) during the postharvest storage period of *Tendral* melons. Each value is the mean of three replicates of five fruits each \pm standard error.

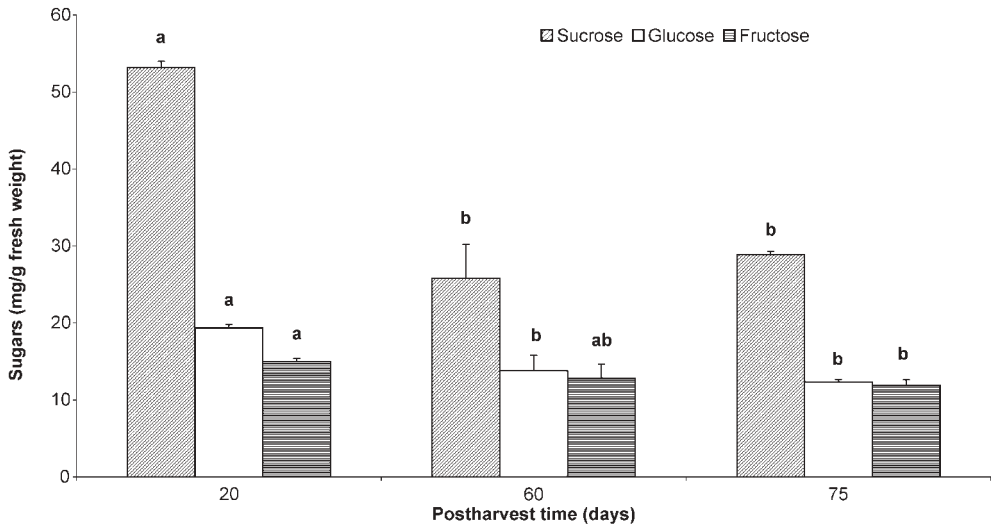

Fig. 2. Variation in sugar content during the 75-days storage period of *Tendral* melons. Each value is the mean of three replicates of five fruits each \pm standard error. Different letters indicate significant differences in a multiple range analysis for 95 % confidence level, on the basis of Tukey's test

Table 2. Protein and ascorbic acid contents and ACC oxidase activity (expressed as ethylene produced) during the postharvest storage period. Each value is the mean of three replicates of five fruits each \pm standard error. Different letters indicate significant differences in a multiple range analysis for 95 % confidence level, on the basis of Tukey's test. * - not determined, FW – fresh weight.

Days after harvest	Protein (mg g ⁻¹ FW)	Ascorbic acid (mg g ⁻¹ FW)	C ₂ H ₄ (nmol g ⁻¹ h ⁻¹)
20	8.48 \pm 0.360 (a)	0.14 \pm 0.009 (a)	46.723 \pm 0.741 (a)
40	12.77 \pm 0.556 (b)	*	*
60	8.40 \pm 0.611 (a)	0.10 \pm 0.003 (b)	58.519 \pm 0.993 (b)
75	4.91 \pm 0.521 (c)	0.08 \pm 0.000 (c)	44.211 \pm 2.954 (a)

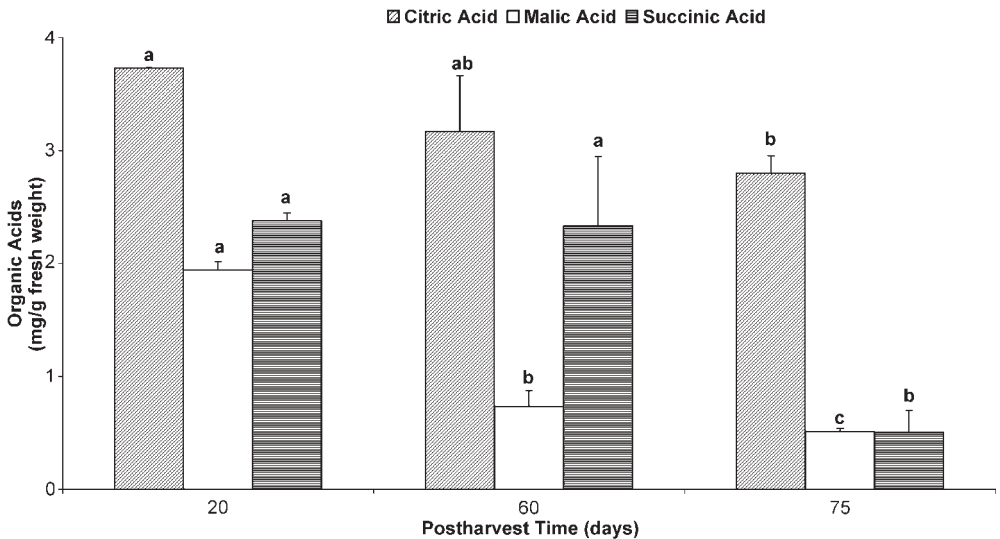

Fig. 3. Variation in organic acid content during the 75-days storage period of *Tendral* melons. Each value is the mean of three replicates of five fruits each \pm standard error. Different letters indicate significant differences in a multiple range analysis for 95 % confidence level, on the basis of Tukey's test.

Furthermore, our data confirm previous findings indicating that sucrose was the predominant sugar (Hubbard et al., 1989), with glucose being the major reducing sugar (Fig. 2). At harvest, sucrose represented about 60.7 % of total sugar content, while glucose and fructose constituted c.a. 22.1 % and 17.1 %, respectively. There was a significant reduction of sugars during the storage period (40 %), due to natural degradation. In fact, they become metabolically consumed in the respiratory chain due to phosphorylated equivalents synthesis (Lester and Bruton, 1986). In melon fruits, these processing capabilities do not seem regular, considering the strong decrease in sucrose content (44.6 %), especially during the first 40 days of storage. Only a slight decline in glucose content (20.5 %) occurred and a minimal reduction in fructose content (5.3 %) was observed. This result suggested that sucrose was

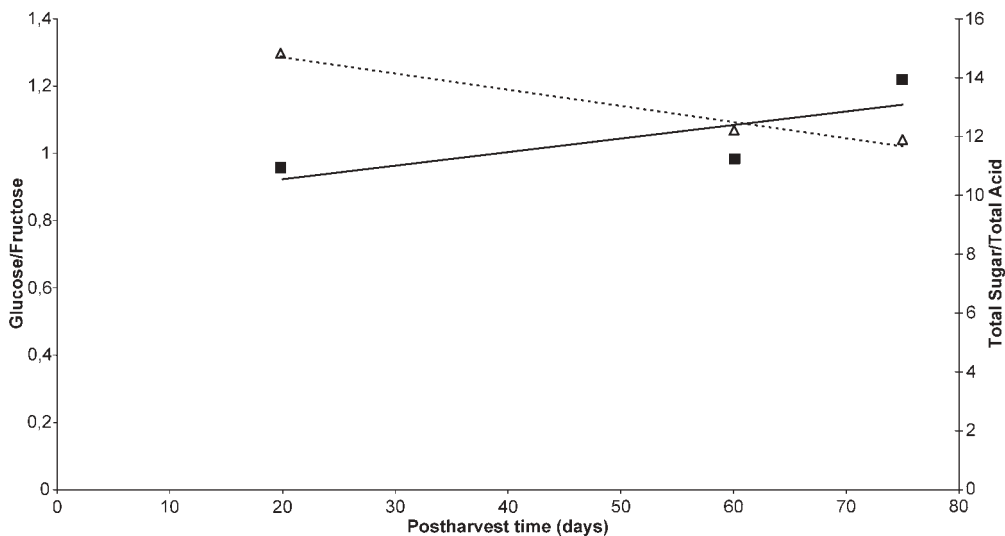

Fig. 4. Glucose/fructose and total sugar/total acid ratios during the storage period of *Tendral* melons (Δ - Glucose/fructose ratio ($r^2 = 0.983$); ■ - Sugar/acid ratio ($r^2 = 0.609$)).

hydrolyzed to its respective monomeric isomers probably due to an increase in the invertase activity (Lingle and Dunlap, 1987; Schaffer et al., 1987; McCollum et al., 1988; Hubbard et al., 1990).

Leach et al. (1989) found that in the cultivars of *Cucumis melo*, citric acid was the major component of the organic fraction which agrees with our findings, since it contributes with about 46 % at harvest (Fig. 3). Malic and succinic acids constituted only 24.1 % and 29.5 %, respectively. By the end of storage, a 53 % decrease of total organic acid content was observed. A similar pattern has long been detected for many other fruits (Kays, 1991). However, as with sugars, this trend is different for the three acids analyzed indicating the existence of other inhibitory steps of these metabolites. In fact, the glucose/fructose ratio diminished during fruit senescence (Fig. 4). Since fructose is “sweeter” than glucose, fruits become more attractive for the consumer. This ratio correlated in 99.2 % with time. The total sugar/total acid ratio displayed an inverse correlation. It increased during the postharvest period showing a correlation of 78 %. The initial content of proteins also increased (Table 2), probably as a result of the turn over of new proteins coupled to senescence. The subsequent decline is certainly due to an enzyme activity (Abu-Goukh and Abu-Sarra, 1993). As previously reported (Evensen, 1983), a huge decrease of the ascorbic acid content (44%) also occurred during the storage period (Table 2). This parameter displays the increasing degradation ratio of the organic molecules (namely proteins and acyl lipids), since the redox equivalents of ascorbic acid are progressively affected. This decrease develops during the storage period (Adisa, 1986). Results published by

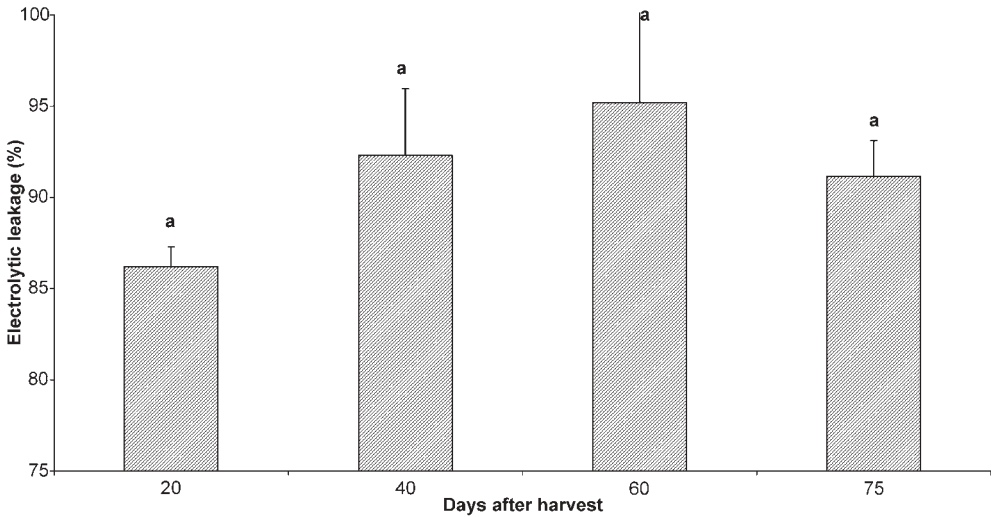

Fig. 5. Electrolyte leakage from *Tendral* melons during the storage period after 3 h of incubation. Each value is the mean of three replicates of five fruits each \pm standard error. Different letters indicate significant differences in a multiple range analysis for 95 % confidence level, on the basis of Tukey's test

Ververidis and John (1991), for *Ogen* melon, indicated that ACC oxidase activity in homogenized extracts supplemented with iron and ascorbate increases rapidly, and then it declines as fruits become overripe. Our data were analogous and eventually also correlated with lipid peroxidation, which is enhanced during storage (Table 3), reflecting the degradation of membrane polar acyl lipids (Lacan and Baccou, 1998), and justifying the evolution of ethylene, probably also implicating its production due to the synthesis of oxyradicals (as shown by the modification of the enzyme activities, SOD and CAT). These alterations of membrane properties were also supported by the measurement of electrolytic leakage from discs of muskmelon pulp. In fact, this process, which is a good indicator of membrane damage (Lacan and Baccou, 1996), slowly increased during the 75 days of storage (Fig. 5). Coupled to the already reported parameters, as seen in Table 3, the progressive failure of antioxidant enzyme systems (namely, the activities of SOD and CAT) suggested an enhanced level of reactive oxygen species. The SOD and CAT activities were significantly lower (by 30.8 % and of 24.4%, respectively). It is well known that the balance between SOD and CAT activities in cells is crucial for determining the steady-state level of superoxide radicals and H_2O_2 (Mittler, 2002). Thus, these data showed a progressive oxidation of *Tendral* melon tissues during postharvest resulting from the accumulation of lipid hydroperoxides in parallel with a decline in the ratio of SOD/CAT activities. In this context, the assumption supports Rogiers et al. (1998). Nevertheless, the rate of glutathione reductase activity was not limiting (Table 3).

Table 3. Activities of enzymes implicated in the control of the oxidative stress in the flesh of winter *Tendral* melon, during storage. For SOD, one unit of activity is defined as the amount of enzyme required to inhibit the reduction rate of cytochrome c by 50 % under the assay conditions. Each value is the mean of three replicates of five fruits each \pm standard error. Different letters indicate significant differences in a multiple range analysis for 95 % confidence level, on the basis of a Tukey's test.

Days after harvest	20 days	60 days
Superoxide dismutase (units mg ⁻¹ Prot)	58.7 \pm 2.0 (a)	40.6 \pm 2.7 (b)
Catalase (μ mol O ₂ mg ⁻¹ Prot min ⁻¹)	10.4 \pm 0.6 (a)	7.8 \pm 0.3 (b)
Ascorbate peroxidase (μ mol Asc mg ⁻¹ Prot min ⁻¹)	1.1 \pm 0.0 (a)	0.7 \pm 0.1 (b)
Dehydroascorbate reductase (μ mol Asc mg ⁻¹ Prot min ⁻¹)	3.2 \pm 0.2 (a)	2.5 \pm 0.1 (a)
Glutathione reductase (μ mol NADPH mg ⁻¹ Prot min ⁻¹)	3.9 \pm 0.2 (a)	5.0 \pm 0.1 (b)
Lipoperoxides (nmol MDA g ⁻¹ FW)	18.9 \pm 0.4 (a)	34.2 \pm 1.1 (b)

The resulting alterations coupled to the oxidative stress during the postharvest period affected *Tendral* melon quality parameters. Twenty days after harvest fruits showed a global consumer acceptance of 14.320 ± 1.031 (a) and this parameter reached 16.412 ± 0.470 by day 60 (b). The main conclusion of this work is that in spite of the alterations of the stored melons a better flavour and aroma developed, mainly due to the acid degradation and eventually implicating alkaloids and sugar accumulation.

Acknowledgements: This work was supported by the Project AGRO DE&D No 191 from EAN-INIAP, Portugal. The authors thank to Eng. Eduardo Leitão (Centro de Estudos de Produção e Tecnologia Agrícolas, Instituto de Investigação Científica Tropical, Tapada da Ajuda, Portugal) for all the advises and help given in HPLC methods and Virgínia Quartim and Ana Paula Ramos (Estação Agronómica Nacional, Oeiras, Portugal) for technical assistance.

References

- Abu-Goukh, A.A., A.F. Abu-Sarra, 1993. Compositional changes during mango fruit ripening. Univ. Khartoum J. Agric. Sci., 11, 33-51.
- Adisa, V.A., 1986. The influence of molds and some storage factors on the ascorbic acid content of orange and pineapple fruit. Food Chem., 22, 139-146.
- Barreiro, M.G., Lidon, F.C., M., Pinto, 2001. Physicochemical characterization of the postharvest senescence of the winter melon *Tendral*. Fruit, 56, 51-58.
- Bartoli, C.G., Simontacchi, M., Montaldi, E., S., Puntarulo, 1996. Oxidative stress, antioxidant capacity and ethylene production during aging of cut carnation (*Dianthus caryophyllus*) petals. J. Exp. Bot., 47, 596-601.
- Böhme, H., W.A., Cramer, 1971. Plastoquinone mediates electron transport between cytochrome b-559 and cytochrome f in spinach chloroplasts. FEBS Lett., 15, 349-351.

- Camara, M.M., Dhez, C., M.E., Torija, 1995. Evaluaciyn de la calidad de zumos, néctares y concentrados de frutas. Alimentaciyn, equipos y tecnologna, 6, 113-116.
- Dalton, D.A., Russel, S.A., Hanus, F.J., Pascoe, G.A., H.J., Evans, 1986. Enzymatic reactions of ascorbate and glutathione that prevent peroxidative damage in soybean root nodules. Proc. Natl. Acad. Sci., 83, 3811-3815.
- Dong, J.G., Fernández-Maculet, J.C., S.F., Yang, 1992. Purification and characterization of l-aminocyclopropane-l-carboxylate oxidase from apple fruit. Proc. Natl. Acad. Sci. USA, 89, 9789-9793.
- Droillard, M.J., Paulin, A., J.C., Massot, 1987. Free radical production, catalase and superoxide dismutase activities and membrane integrity during senescence of petals of cut carnation (*Dianthus caryophyllus*). Physiol. Plant, 76, 149-154.
- Dumas de Vaulx, R., S., Aubert, 1976. Caractéristiques biochimiques, qualité et aptitude a la conservation de melons cultivés sous serre. Ann. Technol. Agr., 25, 309-336.
- Evensen, K.B., 1983. Effects of Maturity at Harvest, Storage Temperature and Cultivar on Muskmelon Quality. HortSci., 18, 907-908.
- Gemma, H., Yuri, M, W., Hong-kong, 1994. Ripening characteristics and chilling injury of banana fruit. I. Effect of strage temperature on respiration, ethylene production and membrane permeability of peel and pulp tissues. Japan. J. Tropic. Agric., 38, 216-220.
- Hardenburg, R.E., Watada, A.E., C.Y., Wang, 1986. Commercial storage of fruit, vegetables and florist and nursery stocks, USDA-ARS Handbook 66.
- Hubbard, N.L., Huber, S.C., D.M., Pharr, 1989. Sucrose phosphate synthase and acid invertase as determinants of sucrose concentration in developing muskmelon (*Cucumis melo* L.) fruit. Plant Physiol., 91, 1527-1534.
- Hubbard, N.L., Pharr, D.M., S.C., Huber, 1990. Sucrose metabolism in ripening muskmelon fruit as affected by leaf area. J. Am. Soc. Hort. Sci., 115, 798-802.
- Hudina, M., F., Stampar, 2000. Free sugar and sorbitol content in pear (*Pyrus communis* L.) cv. Williams during fruit development using different treatments. Acta Hort., 514, 269-274.
- Kays, S.J., 1991. Postharvest physiology of perishable plant products, in: Development of Plants and Plant Parts, Van Nostrand Reinhold Publ., New York, 257-335.
- Lacan, D., J.C., Baccou, 1996. Changes in lipids and electrolyte leakage during the ripening of nonnetted muskmelon fruits. J. Am. Soc. Hort. Sci., 121, 554-558.
- Lacan, D., J.C., Baccou, 1998. High levels of antioxidant enzymes correlate with delayed senescence in nonnetted muskmelon fruit. Planta, 204, 377-382.
- Leach, D.N., Sarafis, V., Spooner-Hart, R., S.G., Wyllie, 1989. Chemical and biological parameters of some cultivars of *Cucumis melo*. Acta Hort., 247, 353-357.
- Lester, G.E., B.D., Bruton, 1986. Relationship of netted muskmelon fruit water loss to postharvest storage life. J. Am. Soc. Hort. Sci., 111, 727-731.
- Lidon, F.C., 1994. Effects of excess copper in rice: biochemical, physiological and ultrastrutural aspects, FCT/UNL Eds, Monte da Caparica, Portugal.
- Lingle, S.E., J.R., Dunlap, 1987. Sucrose metabolism in netted muskmelon fruit during development. Plant Physiol., 84, 386-389.
- Lowry, O.H., Rosebrough, N.J., Farr, A.L., R.J., Randall, 1951. Protein measurement with the Folin phenol reagent. J. Biol. Chem., 193, 265-275.

- McCollum, T.J., Huber, D.J., D.J., Cantliffe, 1988. Soluble sugar accumulation and activity of related enzymes during muskmelon fruit development. *J. Am. Soc. Hort. Sci.*, 113, 399-403.
- McCord, J.M., L., Fridovich, 1969. Superoxide Dismutase: An enzymatic function for erythrocuprein (hemocuprein). *J. Biol. Chem.*, 244, 6049-6055.
- Mittler, R., 2002. Oxidative stress, antioxidants and stress tolerance. *Plant Sci.*, 7, 405-410.
- Nakasano, Y., K., Asada, 1981. Hydrogen peroxide is scavenged by ascorbate-specific peroxidase in spinach chloroplasts. *Plant Cell Physiol.*, 22, 867-880.
- Ogle, W.L., E.P., Christopher, 1957. The influence of maturity, temperature and duration of storage on quality of cantaloupes. *J. Am. Soc. Hort. Sci.*, 70, 319-324.
- Paliyath, G., M.J., Droillard, 1992. The mechanisms of membrane deterioration and disassembly during senescence. *Plant Physiol. Biochem.*, 30, 789-812.
- Pardo, J.E., Alvarruiz, A., Varyn, R., R., Gymez, 2000. Quality evaluation of melon cultivars. *J. Food Quality*, 23, 161-170.
- Patra, M.L., Kar, M., D., Mishra, 1978. Catalase activity in leaves and cotyledons during plant development and senescence. *Biochemie, Physiologie und Pflanzenphysiologie*, 172, 385-390.
- Pintado, C., Lidon, F., Rodrigues, F.M., Barreiro, M.G., M.G., Ferreira, 2003. *Melão Tendral*: da colheita à mesa de Natal. *Frutas, Legumes e Flores*, 71, 24-25.
- Rogiers, S.Y., Kumar, G.N.M., N.R., Knowles, 1998. Maturation and ripening of fruit of *Amelanchier alnifolia nutt.* are accompanied by increasing oxidative stress. *Ann. Bot.*, 81, 203-211.
- Romero-Rodrigues, A., Oderiz, L.V., Hernandez, J.L., J.S., Gandara, 1992. Comparaison de deux méthodes de dosage par CLHP de l'acide ascorbique dans *Carica pentagona*. *Sci. des Aliments*, 12, 593-600.
- Ryall, A.L., W.J., Lipton, 1979. Handling, transportation and storage of fruit and vegetables, vol I, 2nd Ed, AVI. Westport. Conn.
- Schaffer, A.A., Aloni, B., E., Fogelman, 1987. Sucrose metabolism and accumulation in developing fruit of *Cucumis*. *Phytochem*, 26, 1883-1887.
- Simon, E.W., 1977. Leakage from fruit cells in water. *J. Exp. Bot.*, 28, 1147-1152.
- Ververidis, P., P., John, 1991. Complete recovery in vitro of ethylene-forming enzyme activity. *Phytochem.*, 30, 725-727.
- Villanueva, M.J., Tenorio, M.D., Esteban, M.A., M.C., Mendoza, 2004. Compositional changes during ripening of two cultivars of muskmelon fruits. *Food Chemistry*, 87, 179-185.
- Vioque, B., J.M., Castellano, 1994. Extraction and biochemical characterization of 1-aminocyclopropane-1-carboxylic acid oxidase from pear. *Physiol. Plantarum*, 90, 334-338.

GROWTH AND PHOTOSYNTHETIC CHARACTERISTICS AS AFFECTED BY TRIAZOLES IN *Amorphophallus campanulatus* Blume

R. Gopi*, R. Sridharan, R. Somasundaram, G.M. Alagu lakshmanan and R. Panneerselvam

Annamalai University, Division of Plant Physiology, Department of Botany,
Annamalai Nagar-608 002, Tamil Nadu, South India

Received 7 November 2005

Summary. *Amorphophallus campanulatus* (Elephant Foot Yam) is a rich source of starch, essential amino acids and therefore, used as a vegetable. It is cultivated and utilized in various regions of South India. Triazole compounds are widely used systemic fungicides to control diseases in plants and animals. Many of the triazole compounds have both fungi toxic and plant growth regulating properties. Hence, an attempt was made to study the effect of triadimefon, paclobutrazol, and propiconazole on growth and photosynthetic characteristics of *Amorphophallus campanulatus*. Triazole compounds increased total root length, dry weight, moisture content, chlorophyll and carotenoid contents, intercellular CO₂ concentration, net photosynthetic rate (P_N) and water use efficiency (WUE). On the other hand, petiole length, total leaf area, transpiration rate (T_R) and stomatal conductance were decreased. Among the triazole compounds, paclobutrazol showed higher effectiveness than the other two triazole compounds tested.

Keywords: *Amorphophallus campanulatus*, paclobutrazol, plant growth regulators, propiconazole, triadimefon.

Abbreviations: ABA – abscisic acid, C_i – intercellular CO₂ concentration, Cv – cultivar, CRBD – completely randomized block design, DAP – days after planting, EC – electrical conductivity, FYM – farm yard manure, GA – gibberelic acid, IRGA – infra red gas analyzer, PBZ – Paclobutrazol, PCZ – Propiconazole, P_N – photosynthetic rate, RH – relative humidity, TDM – Triadimefon, T_R – transpiration rate, WUE – water use efficiency

*Corresponding author, e-mail: suriyagopi@yahoo.co.in

INTRODUCTION

Plant growth regulators play a regulatory role in many physiological processes associated with growth and development of plants (Thakur and Thakur, 1993). The triazole compounds are the largest and most important group of systemic compounds developed for control of fungal diseases in plants (Siegel, 1981). They tend to be much more effective than many other plant growth regulators and they generally require relatively low levels of application (Davis et al., 1988, Gilley and Fletcher, 1997). The effects of triazoles on hormonal changes, photosynthetic rate, enzyme activities and yield components have been reported by various researchers (Ye et al., 1995, Zhou and Ye, 1996).

Besides cereals and legumes, the tuber crops are regarded as an important food crop with the highest dry matter production (Kurup and Nambiar, 1993). Elephant foot yam (*Amorphophallus campanulatus* Blume) is one of the very high yielding tuber crop used in certain medicinal preparations recommended for piles and dysentery (Sambamurthy and Subramanyam, 1989).

The triazole compounds are mainly used as growth retardants and also stress protectants in many crop plants (Fletcher et al, 2000). However, data on the use of triazole compounds to increase the yield of tuber crops are scanty. Hence, the present study becomes essential to investigate the effect of triazole compounds on the growth and photosynthetic characteristics of *Amorphophallus campanulatus* cv. Pidikarani.

MATERIALS AND METHODS

Plant material

Amorphophallus campanulatus is a robust herbaceous plant with an erect long pseudo stem arising from the underground corm apex bearing a tripartite leaf which is deeply dissected. The root system is fibrous and confined to the top layers of the soil. The corms produced at 60 to 80 DAP. Fresh corms of uniform size were harvested and surface sterilized with 0.2% HgCl₂ solution for 3 min with frequent shaking and thoroughly washed in tap water. The field experiments were laid in CRBD with 7 replicates. The pits with a size of 60x60x45cm were dug at a spacing of 90x90cm. The pits were filled with a soil mixture containing FYM, red soil and sand in a 1:1:1 ratio. The plot size was 5 X 4m with 20 pits in each plot. One cormel was planted in each pit and irrigated with bore well water at a 10-day interval. The soil pH was 6.8. Each plant was treated separately with 1L of aqueous solution containing 20 mg triadimefon, 20 mg paclobutrazol and 20 mg propiconazole on 30, 70 and 110 DAP. Treatment was given by soil drenching. During the study the average day and night temperatures were 30±2 °C and 22±2 °C, respectively and the average RH was 70-

80%. The plants were harvested randomly on 80, 160 and 200 DAP for determination of growth and photosynthetic pigments.

Growth parameters

Total root length, petiole length, leaf area and dry weight of root, tuber and leaves were measured. Moisture content was calculated by subtracting the dry weight from the fresh weight.

Photosynthetic pigments determination

Total chlorophyll and carotenoids in the second leaf of the *Amorphophallus* plants were extracted in 80% acetone. The amount of pigments was determined spectrophotometrically after centrifugation at 3000rpm for 10 min (Welschen and Bergkotte, 1994) and calculated according to Lichtenthaler and Wellburn (1983).

Gas exchange measurements

Net photosynthetic rate (P_N), transpiration rate (T_R), intercellular CO_2 concentration (C_i) and stomatal conductance were measured on fully expanded leaves of three individual plants for each treatment at the respective intervals. Gas exchange measurements were done using IRGA (ADC makes model LCA-3). Measurements of P_N , T_R , C_i and stomatal conductance were done at CO_2 concentration (C_a) of $340 \mu mol^{-1}$, leaf to air vapor pressure difference of 2.5 to 3.5 kPa and photosynthetically active irradiance of $1400 \pm 50 \mu mol m^{-2} s^{-1}$. Water use efficiency (WUE) represents the ratio of carbon assimilated to water lost by transpiration (Turner, 1986). It was calculated by dividing P_N by T_R (Todorov et al., 1992).

RESULTS AND DISCUSSION

Our results indicated that total root length increased significantly after triazole treatment (Table 1, 2, Fig.1). Among the triazoles, TDM showed the strongest effect, followed by PBZ and PCZ. Triazole treatment was found to increase the root growth in cucumber and this was associated with increased levels of endogenous cytokinins (Fletcher and Arnold, 1986). The stimulatory effect of TDM in rooting may be due to an inhibition of GA synthesis and this effect was entirely blocked by the addition of GA (Vettakkorumakankav et al., 1999, Sankhla and Davis, 1999).

Triazole treatment decreased the petiole length in *Amorphophallus* plants (Table 1, 2, Fig.1). Triadimefon causes several pronounced side effects in plants including the development of shorter and more compact shoots in wheat plants (Fletcher and Nath, 1984) and cow pea (Gopi et al., 1999). The possible reason for the shorter stem could be attributed to the inhibition of cell division and elongation of the subapical

Table 1. Triazole-induced changes in growth and photosynthetic parameters of *Amorphophallus campanulatus* on 80th DAP. (values are means of 7 samples, P=0.05 Least Significant Difference)

Parameters	Control	TDM (20mg l ⁻¹)	PBZ (20mg l ⁻¹)	PCZ (20mg l ⁻¹)	LSD (P=0.05)
Total root length [cm plant ⁻¹]	365.81	644.82	498.3	383.22	17.097
Petiole length [cm plant ⁻¹]	21.8	18.3	16.8	17.4	0.672
Total leaf area [cm ² plant ⁻¹]	24.03	17.73	16.56	16.7	2.312
Dry weight of whole plants [g plant ⁻¹]	24.56	49.06	43.52	43.56	1.541
Moisture content of whole plants [g plant ⁻¹]	109.79	136.16	121.78	128.15	2.318
Total chlorophyll (a+b) [mg g ⁻¹ FW]	0.11	0.131	0.127	0.12	0.016
Carotenoids [mg g ⁻¹ FW]	0.018	0.04	0.037	0.033	0.006
Net photosynthesis rate (P _N) [μmol CO ₂ m ⁻² s ⁻¹]	9.25	11.24	11.38	11.31	1.39
Transpiration rate(T _R) [μ mol H ₂ O m ⁻² s ⁻¹]	7.92	5.37	5.67	5.98	0.31
Intercellular CO ₂ concentration [μmol s ⁻¹]	125	145	143	147	10.09
Stomatal conductance [μmol H ₂ O m ⁻² s ⁻¹]	112.15	94.28	93.92	94.12	7.82
Water use efficiency (WUE) [μmol CO ₂ m ⁻² s ⁻¹ / μmol H ₂ O m ⁻² s ⁻¹]	1.168	2.141	2.007	1.891	–

meristem (Sachs et al., 1960). It was shown that S-3307 retarded the plant height in rice plants (Izumi et al., 1984). The growth retarding effects of triazoles could probably be due to an inhibition of GA biosynthesis (Fletcher et al, 2000).

Triazole treatment decreased significantly the total leaf area when compared to the respective controls (Table 1, 2, Fig.1). PBZ treatment was found to reduce the total number of leaves and leaf size in citrus (Swietlik and Fucik, 1988) and *Cymbidium sinense* (Pan and Luo, 1994). The inhibition of GA biosynthesis as well as increased ABA content induced by triazole treatment could be the reason for the inhibition of leaf expansion in the triazole-treated *Amorphophallus campanulatus* plants.

Our results showed that both the dry weight and moisture content of roots and tubers were increased when compared to controls. Paclobutrazol and triadimefon treatments increased the root, tuber dry weight and moisture content to a larger extent (Table 1, 2, Fig.1). It was shown that triadimefon treatment increased the dry weight and moisture content of roots in cucumber (Fletcher and Arnold, 1984), radish (Fletcher and Nath, 1988) and peanut (Muthukumarasamy and Panneerselvam, 1997). The mode of action of PBZ in relation to early tuber development can be

Table 2. Triazole-induced changes in growth and photosynthetic parameters of *Amorphophallus campanulatus* on 160th DAP. (Values are means of 7 samples, P=0.05 Least Significant Difference)

Parameters	Control	TDM (20mg l ⁻¹)	PBZ (20mg l ⁻¹)	PCZ (20mg l ⁻¹)	LSD (P=0.05)
Total root length [cm plant ⁻¹]	452.3	795.7	628.62	492.31	19.512
Petiole length [cm plant ⁻¹]	37.9	29.21	26.2	27.02	1.154
Total leaf area [cm ² plant ⁻¹]	34.58	26.56	25.71	27.31	1.199
Dry weight of whole plants [g plant ⁻¹]	92.33	170.73	164.82	158.29	6.479
Moisture content of whole plants [g plant ⁻¹]	290.15	408.09	391.2	391.17	3.878
Total chlorophyll (a+b) [mg g ⁻¹ FW]	0.145	0.174	0.168	0.167	0.014
Carotenoids [mg g ⁻¹ FW]	0.023	0.052	0.042	0.039	0.01
Net photosynthesis rate (P _N) [μmol CO ₂ m ⁻² s ⁻¹]	18.46	21.68	23.8	21.36	1.45
Transpiration rate [T _R] [μmol H ₂ O m ⁻² s ⁻¹]	13.15	9.81	10.36	9.36	1.06
Intercellular CO ₂ concentration [μmol s ⁻¹]	215	275	269	271	17.08
Stomatal conductance [μmol H ₂ O m ⁻² s ⁻¹]	82.12	73.95	72.81	73.21	6.72
Water use efficiency (WUE) [μmol CO ₂ m ⁻² s ⁻¹ / μmol H ₂ O m ⁻² s ⁻¹]	1.403	2.209	2.2	2.282	–

explained by the inhibitory effect of triazoles on GA levels. The lower GA levels as a prerequisite for tuber formation (Hammes and Nel, 1975) increase the ability of partitioning of assimilates to tuberous organ as observed in potato (Deng and Parange, 1988) and gladiolus (Steinitz et al., 1991).

The results of the present study support the observation of Sankhla et al. (1985) and Williamson et al. (1986) for increased leaf dry weight per unit leaf area under triazole treatment in soybean and peach. Triazoles were found to increase the cytokinin content in many plants like pumpkin, oil seed and rape seedlings (Grossmann, 1992). The increased cytokinin levels might increase cell division and thereby lead to increased dry weight in the triazole-treated Elephant Foot Yam plants.

Treatment with triazoles increased chlorophyll and carotenoid contents (Table 1, 2, Fig. 2). Earlier data have shown that TDM treatment increases chlorophyll content in leaves of tomato (Buchenauer and Rohner, 1981), radish (Muthukumarasamy and Panneerselvam, 1997) and cowpea (Gopi et al., 1999). PBZ increased chlorophyll content, fresh weight and leaf area basis and this may be partly due to the observed increase in mass of the root system which is the major site of cytokinin biosynthesis

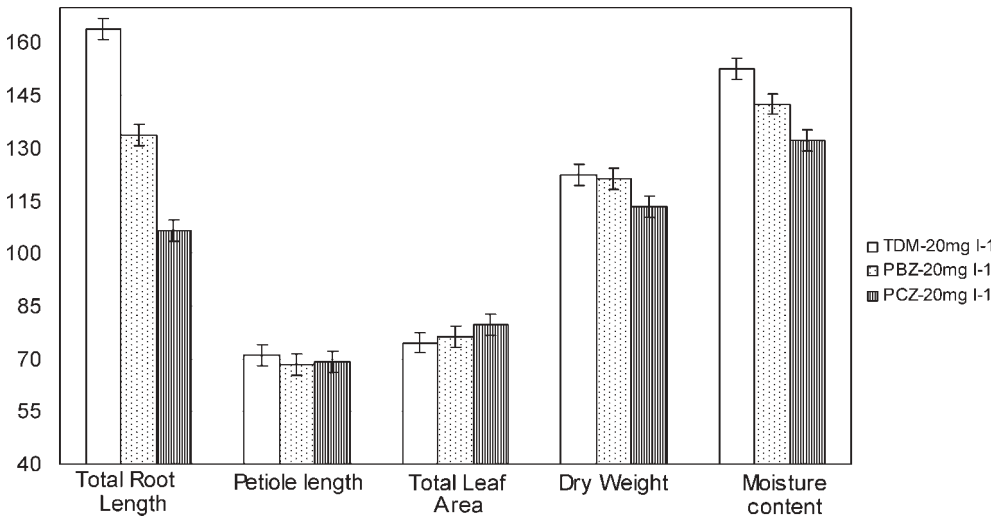

Fig.1. Effect of triazoles on percentage changes in different growth parameters of *Amorphophallus campanulatus* 200 DAP.

(Sopher et al., 1999). The increase in cytokinin levels was associated with stimulated chlorophyll biosynthesis (Fletcher et al., 2000).

Net photosynthetic rate was increased after triazole application (Table 1, 2, Fig. 2). Similar results were observed in PBZ-treated apple (Hong et al., 1995) and triadimefon-treated radish (Panneerselvam et al., 1997). In radish TDM increased P_N along with intercellular CO_2 concentration and stomatal conductance (Panneerselvam et al., 1997). The increased intercellular CO_2 concentration and stomatal conductance may be the reason for the increased P_N in *Amorphophallus* plants. Both increased chlorophyll content and photosynthesis after triazole application were also reported for rice seedlings (Guirong et al., 1995) and bhendi (Sujatha et al., 1999).

The rate of transpiration was lowered in triazole-treated plants at all stages of growth (Table 1, 2, Fig.2). Triadimefon treatment increased the level of ABA content in various plants (Davis et al., 1986, Fletcher and Hofstra, 1988). This in turn induced stomatal closure, thereby decreasing the transpiration rate. A decrease in transpiration rate may have increased the moisture content in the *Amorphophallus campanulatus* plants. Similar results were observed in triadimefon-treated wheat (Sairam et al., 1989) and radish plants (Panneerselvam et al., 1997). Besides, triadimefon treatment increased the ABA content in bean (Asare-Boamah et al., 1986).

Triazole treatment increased the intercellular CO_2 concentration (Table 1, 2, Fig. 2). Similar results were observed in BAS. III W treated maize (Kasele et al., 1995) and *Raphanus sativus* (Panneerselvam et al., 1997). On the other hand, triazole treatment decreased stomatal conductance in *Amorphophallus* plants (Table 1, 2, Fig. 2). Triazole caused partial closure of stomata in mulberry, thereby reducing the T_R

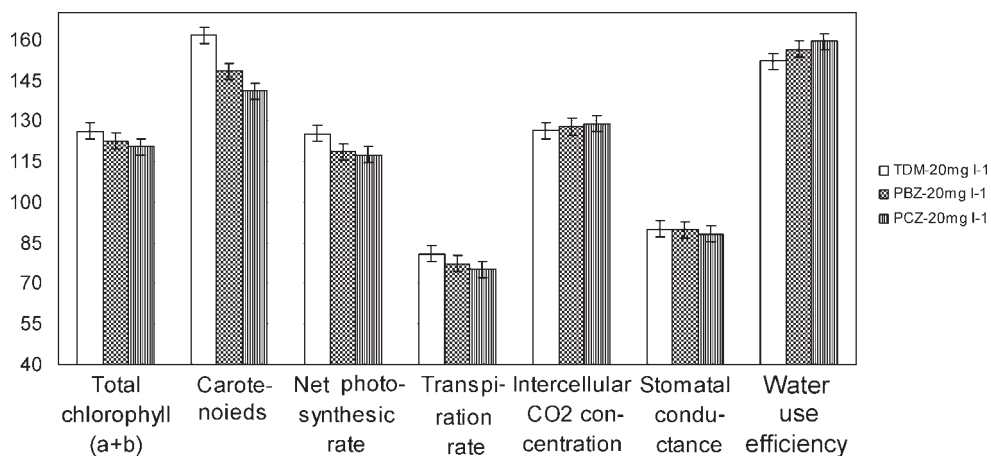

Fig.2. Effect of triazoles on percentage changes in different photosynthetic parameters of *Amorphophallus campanulatus* 200 DAP..

(Sreedhar, 1991) in bean (Asare-Boamah et al., 1986) and oil seed rape (Butler et al., 1988). Our results showed increased WUE in *Amorphophallus* plants (Table 1, 2, Fig. 2). Similar results were reported for TDM-treated sunflower (Wamble and Culver, 1983). PBZ increased the WUE in *Pseudotsuga menziesii* and *Pinus cornata* seedlings (Vanden, 1996). Triazole induced partial closure of stomata and increased intercellular CO₂ concentration. This may be the reason for the increased WUE in the treated plants.

References

- Asare Boamah, N.K., G. Hofstra, R.A. Fletcher, E.B. Dumbroff, 1986. Triadimefon protects bean plants from water stress through its effects on ABA. *Plant Cell Physiol.*, 27, 383-390.
- Buchenauer, H., E. Rohner, 1981. Effects of Triadimefon and Triadimenol on growth of various plant species as well as on gibberellin content and sterol metabolism in shoot of barley seedlings. *Pest. Biochem. Physiol.*, 15, 58-70.
- Butler, D.R., E.Pears, R.D.Child, P.Brain, 1988. Effect of triazole growth retardants on oil seed rape, photosynthesis of single leaves. *Ann. Appl. Biol.*, 114, 331-337.
- Davis, T.D., N. Sankhla, A. Upadhyaya, 1986. Paclobutrazol: a promising PGR. In: Purohit, S.S. (ed.) *Hormonal regulation of plant growth and development*. Agro Botanical Publishers, Bikaner, India, 3, 311-331.
- Davis, T.D., G.L. Steffens, N. Sankhla, 1988. Triazole plant growth regulators. In: Janick J. (ed.) *Hort. Rev.* Timber Press, Portland, Oregon, 10, 63-105.
- Deng, R., P.K. Parange, 1988. Effect of paclobutrazol (PP 333) on ¹⁴C-assimilate partitioning potato (*Solanum tuberosum* L.). *Hort. Sci.*, 23, 155.

- Fletcher, R.A., A.Gilley, T.D.Davis, N. Sankhla, 2000. Triazoles as plant growth regulators and stress protectants. *Hort. Rev.*, 24, 55-138.
- Fletcher, R.A., V.Arnold, 1986. Stimulation of cytokinins and chlorophyll synthesis in cucumber cotyledons by Triadimefon. *Physiol. Plant.*, 66, 197-201.
- Fletcher, R.A., V. Nath, 1984. Triadimefon reduces transpiration and increases yield in stressed plants. *Physiol. Plant.*, 62, 422-424.
- Fletcher, R.A., G.Hofstra, 1988. Triazole as potential plant protectants. In sterol biosynthesis inhibitors in plant production. Eds. D Berg, M Plempel Ellis Horwood Ltd, Cambridge, 321-331.
- Gilley, A., R.A. Fletcher, 1997. Relative efficiency of paclobutrazol, propiconazole and tetraconazole as stress protectants in wheat seedlings. *Plant Growth Regul.*, 21, 169-175.
- Gopi, R., B.M. Sujatha, S.N. Rajan, L. Karikalan, R. Panneerselvam, 1999. Effect of Triadimefon in the NaCl stressed cowpea (*Vigna unguiculata*) seedlings. *Indian J. Agric. Sci.*, 69, 743- 745.
- Grossmann, K., 1992. Plant growth reterents: Their mode of action and benefit for physiological research, In: C.M. Karassan, L.C Van Loon. And D. Vereugdenhil (ed.). *Progress in plant growth regulation*. Kluwer Academic Publishers, Netherlands pp. 788-797.
- Guirong, C.,X.Lin, W.Kaijiun, Z.A.Yan, P.Yijiu, I.Yuming, W.M.Xiang, 1995. The physiological and yield increasing effects of multi-effect triazole treatment of green house rice seedling. *Henan Nongye Kexue*, No.2, 2-4. (ch, 5 ref). Xinyang Higher Agri. Training School. China.
- Hammes, P.S., P.C.Nel, 1975. Control mechanisms in tee tuberization process. *Potato Res.*, 18, 262-272.
- Hong, Y., Y. Zhimim, Y.Jingyl, 1995. Biological response of *Hosta plantaginea* to mepiquat chloride and paclobutrazole. *J.Nanjing Agricultural Univ.China*, 18(3), 18-22.
- Izumi, K.,I. Yamaguchi, A. Wada, H. Oshio, N. Takahashi, 1984. Effect of new plant growth retardant (E)-1-(4-chlorophenyl)-4,4-dimethyl-2-(1,2,4-triazol-1-yl)-1-penten-3-ol (S-3307) on the growth and gibberellin content of rice plants. *Plant Cell Physiol.*, 25, 611-617.
- Kasele, I.N., J.F. Shannahan, D.C. Nielsel, 1995. Impact of growth retardants on corn leaf morphology and gas exchange traits. *Crop sci.*, 35(1), 190-194.
- Kurup, K.B., Nambiar, 1993. Tuber crops in India, an overview. *Indian Horti.*, 33(3), 4-7.
- Lichtenthaler, H., A. Wellburn, 1983. Determination of total carotenoids and chlorophyll *a* and *b* of leaf extracts in different solvents. *Biochem. Soc.Trans.*, 603, 561-592.
- Muthukumarasamy, M., R. Panneerselvam, 1997. Triazole induced protein metabolism in the salt stressed *Raphanus sativus* seedlings. *J. Indian Bot. Soc.*, 76, 39-42.
- Pan, R.C., Y.X.Luo, 1994. Effect of PP 333 on growth, development and leaf structure of *Cymbidium sinensis*. *Acta Horti. Sinica.*, 21(3), 269-272.
- Panneerselvam, R., M. Muthukumarasamy, L. Karikalan, 1997. Triadimefon enhances growth and net photosynthetic rate in NaCl stressed plants of *Raphanus sativus* L. *Photosyn.*, 34, 605-609.

- Sachs, R.M., A. Lang, C.F. Bretz, J. Roach, 1960. Shoot histogenesis sub-apical meristematic activity in a canescent plant and the action of gibberellic acid and AMO-1618. *Amer. J. Bot.*, 47, 260-266.
- Sairam, R.K., P.S. Desmukh, D.S. Shukla, K.G., Wasnik, S.R. Kushwaha, 1989. Effect of Abscisic acid and Triadimefon on photosynthesis and nitrate reductase activity during water stress in wheat. *Indian J. Plant. Physiol.*, 32(1), 51-56.
- Sambamurty, A.V.S.S., N. Subramanyam, 1989. A text book of economic botany, Willey Estren Lid., New Delhi., India. pp. 294-296.
- Sankhla, N., T.D. Davis, A. Upadhyaya, D. Sankhla, R.H. Walsler, B.N. Smith, 1985. Growth and Metabolism of soybean as affected by Paclobutrazol. *Plant Cell Physiol.*, 26, 913-921.
- Sankhla, N., T.D. Davis, 1999. Use of biosynthesis inhibitors for controlling woody plant growth. *Proce. Plant Growth Regul. Soc. Amer.*, 26, 97-104.
- Siegel, M.R., 1981. Sterol-inhibiting fungicides: Effects on sterol biosynthesis and sites of action. *Plant Dis.*, 65, 986-989.
- Sopher, R.C., M.Krol, N.P.A. Huner, R.A. Fletcher, 1999. Chloroplastic changes associated with paclobutrazole induced stress protection in maize seedling. *Can. J. Bot.*, 77, 1-12.
- Sreedhar, V.M., 1991. Proline accumulation and reduced transpiration in leaves of triazole treated mulberry plant. *Indian Bot. Repor.*, 10, 1-5.
- Steinitz, B.A., A. Cohen, Z. Golberg, M. Kochba, 1991. Precocious gladiolus corn formation in liquid shake cultures. *Plant Cell Tiss. Org. Cult.*, 26, 63-70.
- Sujatha, B.M., R. Gopi, L. Karikalani, S.N. Rajan, R. Panneerselvam, 1999. Effect of triadimefon treatment on bhendi (*Abelmoschus esculantus* (L.) Moench.) seedlings under salinity condition. *Indian J. of Plant Physiol.*, 4, 307-310.
- Swietlik, D., J.E. Fucik, 1988. Responses of field-grown grape fruit trees to XE-1019 and paclobutrazol. In: R. Geren, K. Meadel (ed.). *Proc. VI. Internat. Citrus Conf. Balaban Publ., Philadelphia*, pp. 941-946.
- Thakur, P.S., A. Thakur, 1993. Influence of triacontanol and mixtalal during plant moisture stress in *Lycopersion esculantum*. *Plant Physiol. Biochem.*, 31(3), 433-439.
- Todorov, D., V. Alexieva, E. Karnanov, D. Velihko, V. Velikova, 1992. Effect of certain dicarboxylic acid monoesters on growth, chlorophyll content, chlorophyllase and peroxidase activities and gas-exchange of young maize plants. *J. Plant Growth Regul.*, 11, 233-238.
- Turner, N., 1986. In: *Advance in agronomy, crop water deficits. A decade of progress.* Brady, N.C., (ed.). Academic press, London, 39, 1-43.
- Vanden, D.R., 1996. Drought resistance and water use efficiency of conifer seedlings treated with paclobutrazol. *New Forests.* 11(1), 581-583.
- Vettakkorumakankav, N.N., D. Falk, P. Sexena, R.A. Fletcher, 1999. A crucial role for gibberellins in stress protection of plants. *Plant Cell Physiol.*, 40(5), 542-548.
- Wamble, R.L., E.B. Culver, 1983. The influence of paclobutrazol, a new growth regulator on sunflower. *J. Amer. Soc.*, 108, 122-125.
- Welschen, R., M. Bergotte, 1994. *Ecophysiology. Handbook of methods.* Department of plant Ecology and Evolutionary Biology, The Netherlands.

- Williamson, J.G., D.C. Costom, L.W.Griames, 1986. Growth response of peach roots to soil and foliar applied paclobutrazole. Horti. Sci., 21, 1001-1003.
- Ye, Q.F., W.J. Zhou, W.F.Xi., J.Y.Fang, 1995. Effects of S-3307 on levels of endogenous (IAA, ABA and ZT) and physiological of rape seedlings. Acta Agri. Zhejiang, 7, 451-456.
- Zhou, W.J., Q.F Ye, 1996. physiological and yield effects of uniconazole on winter rape (*Brassica napus* L.). J. Plant Growth Regul., 15, 69-73.

STUDY OF LASER-INDUCED FLUORESCENCE SIGNATURES FROM LEAVES OF WHEAT SEEDLINGS GROWING UNDER CADMIUM STRESS

K. B. Mishra^{1, 2, 3*} and R. Gopal^{1, 2}

¹Laser and Spectroscopy Laboratory, Department of Physics; ²M. N. Saha Centre of Space Studies, IIDS, Nehru Science Centre; University of Allahabad, Allahabad - 211002, India; ³Department of Dynamic Biological Systems, Institute of Systems Biology and Ecology CAS, Zamek 136, 37333 Nove Hradky, Czech Republic

Received 7 July 2005

Summary. Steady state LIF spectra using 488 nm of cw Ar⁺ laser and 355 nm of pulsed Nd:YAG laser, fluorescence induction kinetics using 488 nm laser light were studied in wheat seedlings exposed to increasing cadmium (Cd) concentrations (0.01, 0.1, 1.0 and 2.0 mM). In addition, some growth parameters and pigment content were also measured. The LIF spectra of the leaves exhibited two characteristic bands at 685 nm and 730 nm registered at 488 nm excitation wave length and four bands at around 450 nm, 520 nm, 685 nm and 735 nm at 355 nm excitation wave length. The peak parameters of the bands were calculated by Gaussian curve fitting of the LIF spectra. The result showed higher intensity of the red band (685 nm) as compared to the far-red band (730 nm) in the case of 488 nm excited spectra, however, 355 nm excited chlorophyll (Chl) fluorescence spectra exhibited a higher value in the far-red intensity. The plant vitality index (Rfd) of the plants was also calculated for both Chl fluorescence bands using the fluorescence induction kinetics curve. The decrease in plant growth parameters as well as Rfd values at 685 nm and 735 nm in response to increasing Cd concentrations could be considered as symptoms of Cd toxicity. Variations in the Chl FIR and other fluorescence ratios of intensities, bandwidth and band area were also observed. Thus, we demonstrate the use of the LIF spectra for rapid detection of Cd stress in wheat plants.

* Corresponding author, e-mail: kumud28@yahoo.com, spectra2@sancharnet.in

Keywords: cadmium stress, chlorophyll content, fluorescence intensity ratio, fluorescence induction kinetics, laser-induced fluorescence, wheat seedlings.

Abbreviations: Cd – cadmium; Chl - chlorophyll; Chl FIR – chlorophyll fluorescence intensity ratio; FIR - fluorescence intensity ratio FWHM – full width at half intensity maximum; Fm – maximum fluorescence yield; Fd - fluorescence decay; Fs – steady state fluorescence; ICCD - intensified charge coupled device; LIF - laser induced fluorescence; PMT - photo multiplier tube; Rfd - relative fluorescence decay also called plant vitality index; UV - ultra violet; UV-A - ultra violet-A radiation between 320-400 nm.

INTRODUCTION

The study of LIF spectra in plants under different stress is suitable for the remote sensing of the near distance and has the potential application for further development into a far distance remote sensing system for monitoring the health of terrestrial vegetation crops and forests. This technique can be used for quick determination of plant stress responses even before any visible symptoms have appeared. The fluorescence emission spectrum of higher plants excited by UV light consists of four bands centred at 450 nm (blue), 520 nm (green), 685 nm (red) and 735 nm (far-red). The red and far red bands are due to the fluorescence of chlorophyll while blue and green fluorescence is emitted by cinnamic acid with ferulic acid as a main substance and other plant phenolics covalently bound to the cell walls of the epidermis and mesophyll layer of the leaves (Lichtenthaler and Schweiger, 1998; Buschmann et al., 2000). These fluorescence bands were found to change in relative intensity depending on the species studied (Johnson et al., 2000) and stress conditions (Chappelle et al., 1984; Lichtenthaler et al., 1991; Stober et al., 1994; Lang et al. 1991). Stress can also shift the peak position of the different bands (Subhash and Mohanan 1997; Gopal et al. 2002). Many groups have done extensive research and suggested that Chl FIR as well as FIRs resulting from blue, green, red and far-red bands can give fruitful information about the state of plant health. Moreover, the possible application of FIRs in the remote sensing of vegetation is limited by the lack of information regarding the physiological meaning of FIRs with respect to stresses.

Photosynthetic quantum conversion is affected by exposure to a range of biotic and abiotic stresses. Heavy metals enter into the ecosystem through drainage water, river canal system carrying industrial effluents and air. Plants absorb and accumulate heavy metals in leaves and impede various physiological activities (Bazzaz and Govindjee, 1974; Carlson et al., 1975). Among the heavy metals, Cd is a highly toxic element and its ions can readily be translocated into the leaves of several crop species, such as soybean and wheat (Haghiri, 1973). It has been shown that Cd decreases

CO₂ assimilation (Krupa and Baszynski, 1995), can generate oxidative stress (Schutzendubel et al., 2001) and leads to wilting (Barcelo and Poschenrieder, 1990). The primary mechanisms of Cd toxicity include altered catalytic function of enzymes, damaging of cell membranes and inhibition of root growth (Kastori et al., 1992). Toxic concentrations of heavy metals in the environment affect the physiology of the plants at several levels and the photosynthetic machinery is one of the major targets. Detection of Cd stress in wheat plants which could be useful for precise farming practices in future remote sensing of crops via ground operated or air-born lidar system was the main object of the present study.

MATERIALS AND METHODS

Plant material and growth conditions

Healthy and uniform in size wheat seeds (*Triticum aestivum* v- RR.21) were disinfected and soaked in sterilized double distilled water over the double layers of filter paper for two days. Besides, 25 germinating seedlings of the same size were selected and transferred carefully into Petri plates, each containing an equal amount of 0.2 strength modified Rorison medium for control plants and different concentrations of Cd (0.01, 0.1, 1.0 and 2.0 mM) applied as CdCl₂·2H₂O for treated plants. The composition of the nutrient solution was as follows (in mM): 0.4 Ca(NO₃)₂, 0.2 MgSO₄, 0.2 KH₂PO₄; (in mM): 0.1 CuSO₄·5H₂O, 0.2 ZnSO₄·7H₂O, 9.2 H₃BO₃, 1.8 MnCl₂·4H₂O, 0.2 NaMoO₄·2H₂O and 10 FeEDTA. The pH of the nutrient solution was adjusted to 6.5. The plants were grown in a growth chamber at a photon flux density of 175 μmol m⁻² s⁻¹, at room temperature under a 12/12 h dark/light photoperiod. After five days intact leaves were harvested and used for LIF study and determination of Chl *a*, *b* and carotenoids.

Experimental setup for blue laser light excitation studies

The laser spectrofluorimeter used in the present study was a computer controlled Acton 0.5 m monochromator with a data acquisition system. A cw Ar⁺ laser (Spectra Physics, USA Model 2016) operating at 488 nm (2 mW) was used for exposing the intact leaves with the help of the beam expander. The laser beam fell on the intact leaves by reflecting the beam using two front surface polished mirrors and passing through a beam expander. The mirror and the beam expander were aligned to obtain about 2.0 cm² expanded laser beam at the surface of the leaves. The fluorescence light was collected using a convex lens on the slit of the monochromator having resolution 0.03 nm and reciprocal linear dispersion of 1.1 nm mm⁻¹, with R928 PMT detector. The steady-state spectra were recorded in the spectral region 650 – 800 nm. The PMT signals were sent to the computer and the data collected were analysed

using Grams-32 (Galactic) software. The laser light intensity was measured by a power meter (Spectra-Physic). The experimental set-up used to study fluorescence parameters is presented in Fig. 1. Each spectrum presented in the paper with 488 nm excitation light is an average of fifteen different spectra.

Experimental setup for UV-A laser light excitation studies

Third harmonics (355 nm) of Nd:YAG laser (Spectra Physics - Quanta Ray), operating at 10 Hz with a pulse width of 10 ns and pulse energy of 2.5 mJ was used for the excitation of plant leaves. The fluorescence radiation was collected using a convex lens on the slit of a computer-controlled Spex 0.32 m monochromator with 600 grs/mm grating having resolution of 0.12 nm and linear reciprocal dispersion 5.28 nm mm^{-1} , fitted and Spex TE cooled ICCD detector. The steady state LIF spectra were recorded in the region 418-766 nm. The ICCD signals were collected on the computer using SpectraMax software and the data were analysed using Grams-32 (Galactic) software. The detector took “snap shots” and SpectraMax were used to combine them into a single spectrum or present them separately. Multiple spectra were recorded for control and Cd-treated leaves with 20 accumulations in three replicates. The multiple spectra were merged into a single data file for each measurement.

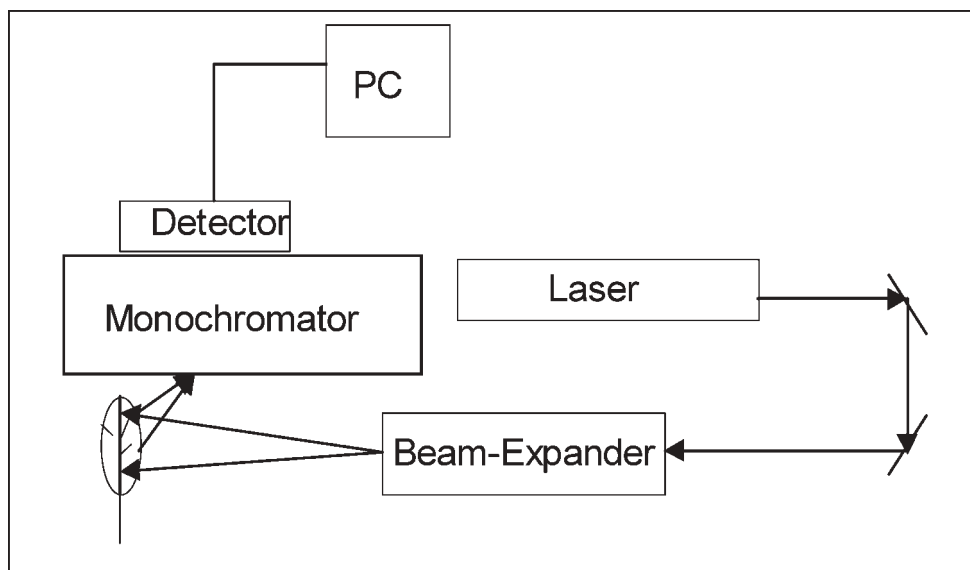

Fig. 1. Experimental scheme for investigation of LIF spectra. The set-up consists of a laser as an excitation source, a beam expander, a computer-controlled monochromator and a detector system (details are given in Materials and Methods).

Experimental setup for fluorescence induction kinetics (Kautsky effect)

The fluorescence induction kinetics of pre-darkened leaves was recorded on an Acton 0.5 m monochromator with the intensity vs time scan mode of the RD CARD software exposed with 488 nm of Ar⁺ laser (82 $\mu\text{mol m}^{-2} \text{s}^{-1}$ PFD). The plants were dark adapted for 20 min and were placed in front of the entrance slit of the monochromator to record the kinetics at 685 nm and 735 nm for 5 min.

Measurements of LIF spectra of intact leaves and their curve-fitting

Intact leaves were dark adapted for 20 min and stacked in a black wood cardboard. The geometry was set up in such a way that the fluorescence was excited at an angle of 60° and sensed at an angle of 30° to the leaf surface. Fluorescence radiation emitted by the leaf was collected at the entrance slit of a monochromator using a convex lens and fluorescence induction kinetics were measured for 5 min using 488 nm of Ar⁺ laser followed by steady-state fluorescence spectra using 488 nm and 355 nm laser lights. The background signals of the spectra were also recorded for each sample and subtracted from the respective data file. The curve fitting of the recorded spectra was done using Grams-32 software with the Curve-fit.AB program. The peak parameters, such as exact peak position, intensity, bandwidth and band area were determined. The Curve-fit is based on the original algorithm of nonlinear peak fitting as described by Marquardt and also known as the Levenberg-Marquardt method. Gaussian spectral function for the curve fitting provides the reasonable matching of the spectral data with good F-statistics, standard errors for peak amplitude, peak centre and bandwidth or FWHM (Subhash and Mohanan, 1997). The intensities of the fluorescence bands were corrected in light of response curves of the used grating and detector and normalised fluorescence ratios were calculated.

Determination of pigments

Chlorophyll and carotenoids were extracted in 80% acetone. Concentrations of total Chl, Chl *a* and Chl *b* were determined using a spectrophotometer (model 108, Systronic, India) according to the method of Arnon (1949), however, the true values for Chl *a*, *b* and total Chl were calculated by applying the correction equation given by Porra (2002). The level of total carotenoids was determined using the extinction co-efficient of $E_{473} = 2500$ absorbance units as an average value (Goodwin, 1954).

RESULTS AND DISCUSSION

Pigment content and pigment ratio

An inhibition of the growth of wheat seedlings was observed as a result of exposure to Cd for 5 days. Chl *a*, *b* and total Chl content decreased with increasing Cd concentration while carotenoids content was minimum at 0.01 mM Cd and it increased with increasing Cd concentration (Table 1). Our results showed also that Cd inhibited shoot length. The fresh weight of the leaves was slightly stimulated at 0.01 mM Cd while higher Cd concentrations inhibited strongly the fresh weight of the seedlings. Larsson et al. (1998) and Baryla et al. (2001) found that even 5 mM Cd reduced growth, Chl content, photochemical quantum yield and led to stomatal closure in *Brassica napus*. The Chl *a* /*b* ratio increased by 8.1% at 0.01 mM Cd followed by a decrease with increasing Cd concentration (Fig. 2B). A rapid decrease in the total Chl/carotenoids ratio with increasing Cd concentration was also observed. Babani and Lichtenthaler (1996) reported that total Chl/carotenoids ratio increased with greening of barley seedlings. Bazzaz et al. (1974) mentioned that cadmium caused degradation in Chl and carotenoids, inhibited their biosynthesis, and induced oxidative stress by disturbing the chloroplast. Carotenoids are known as antioxidants that reduce oxidative stress by acting as scavengers of reactive oxygen species (Stratton and Liebler, 1997). Therefore, the increasing content of carotenoids in Cd-treated wheat seedlings could reflect the overall level of antioxidant defence against stress. Han et al. (2005) reported an increase in carotenoids content in some lower plants under oxidative stress.

Table 1. Content of photosynthetic pigments and growth parameters measured in control and Cd-treated wheat seedlings.

Cd concentration(mM)	Chl <i>a</i> (mg g ⁻¹ FW)	Chl <i>b</i> (mg g ⁻¹ FW)	Total Chl (mg g ⁻¹ FW)	Carotenoids (mg g ⁻¹ FW)	Shoot length (cm)	Fresh weight (mg/shoot)
0.00	0.76 ± 0.01	0.44 ± 0.02	1.20 ± 0.04	0.18 ± 0.01	10.4 ± 0.6	163 ± 1
0.01	0.71 ± 0.03	0.38 ± 0.01	1.09 ± 0.03	0.17 ± 0.02	9.8 ± 0.6	167 ± 3
(-6.6)	(-13.6)	(-9.2)	(-5.6)	(-5.8)	(2.5)	
0.10	0.64 ± 0.02	0.43 ± 0.02	1.07 ± 0.04	0.25 ± 0.01	6.9 ± 0.6	124 ± 2
(-15.8)	(-2.3)	(-10.8)	(38.9)	(-33.7)	(-23.9)	
1.00	0.47 ± 0.01	0.38 ± 0.03	0.85 ± 0.02	0.27 ± 0.02	6.4 ± 0.2	112 ± 3
(-38.2)	(-13.6)	(-29.2)	(50.0)	(-38.5)	(-31.3)	
2.00	0.39 ± 0.02	0.30 ± 0.01	0.69 ± 0.02	0.29 ± 0.01	4.2 ± 0.1	48 ± 1
(-48.7)	(-32.8)	(-42.5)	(61.1)	(-59.6)	(-70.6)	

Mean (n=3) ± SD of triplicate.

*Values in parentheses represent the percent increase or decrease compared to the control.

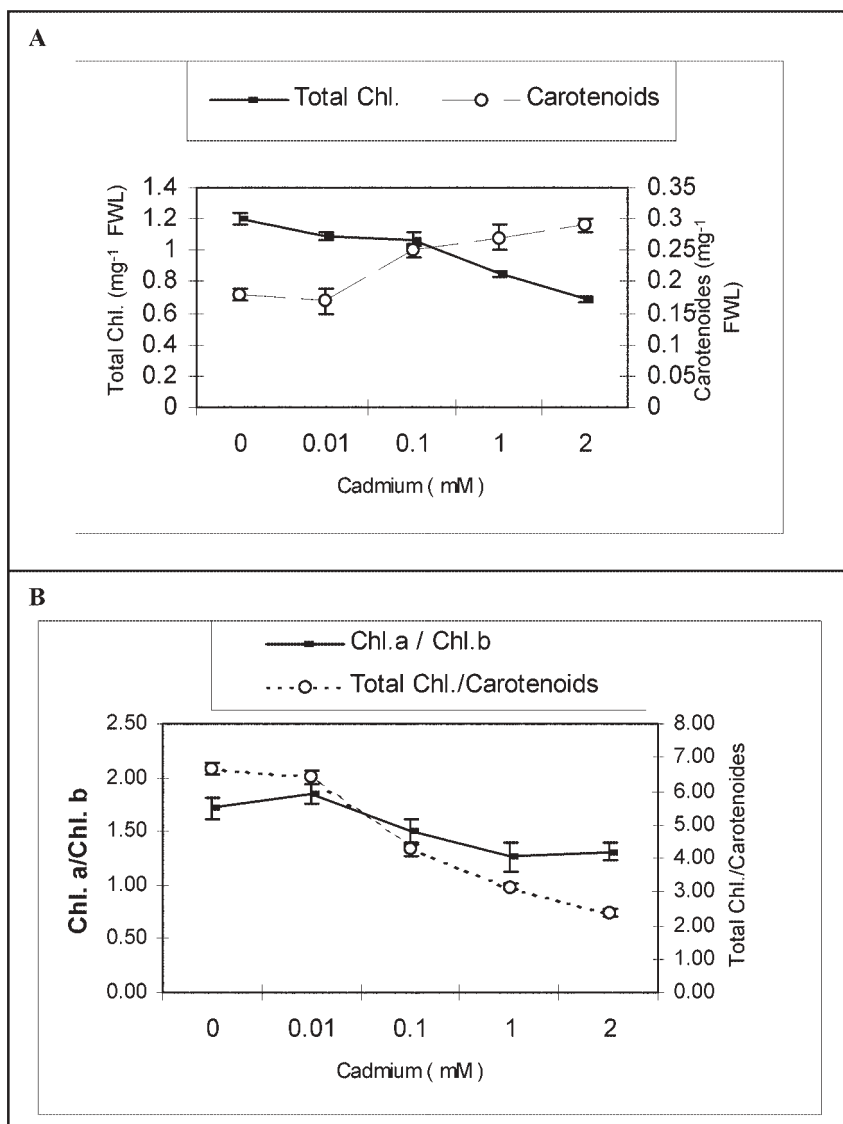

Fig. 2. Variations in (A) total chlorophyll and carotenoids content, (B) Chl *a*/Chl *b* and total Chl/carotenoids ratios in Cd-treated wheat plants. Points represent the mean value ($n=3$) and bars represent the standard error (SE).

LIF spectra from intact leaves of the seedlings

The curve-fitted steady state level LIF spectra excited by 488 nm (blue) and 355 nm (UV-A) laser light are presented in Fig. 3 and Fig. 4, respectively. The sum of squared deviation (c^2) and correlation coefficient (R^2) of the fitted LIF spectra are presented

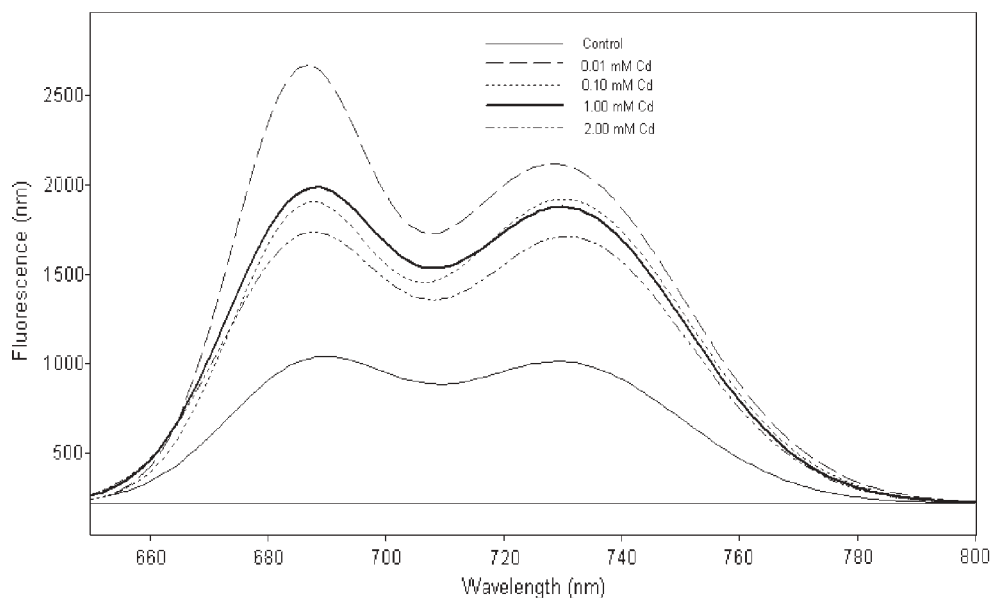

Fig. 3. Gaussian curve fitted steady state LIF spectra of control and Cd treated wheat plants excited by 488 nm of Ar^+ laser. Each spectrum in the figure is the average of fifteen spectra.

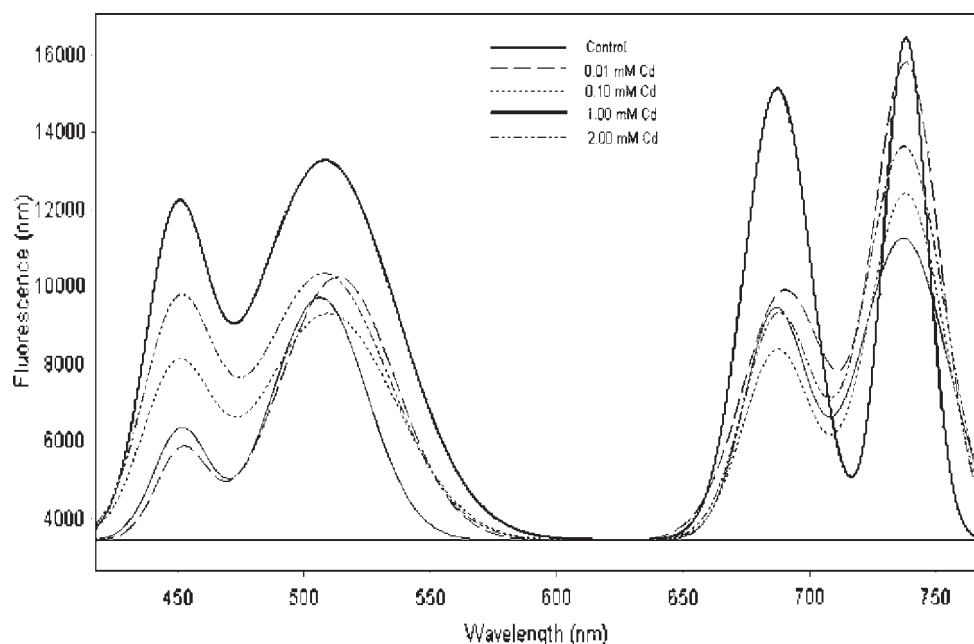

Fig. 4. Gaussian curve fitted steady state LIF spectra of control and Cd treated wheat plants excited by 355 nm of Nd:YAG laser. The fluorescence signal was collected using an ICCD detector system by choosing seven wavelength regions with twenty accumulations for each region with three replicates. The multiple spectra were merged into a single data file within the region 418-766 nm.

Table 2. Curve - fitting parameters reduced chi² (χ^2) and correlation (R^2) of the fitted LIF spectra of control and Cd-treated wheat seedlings at 488 nm and 355 nm excitation wave lengths. These parameters show the quality of fitting of the measured LIF spectra.

Cd concentration (mM)	488 nm excitation		355 nm excitation	
	Reduced Chi ² (χ^2)	Correlation (R^2)	Reduced Chi ² (χ^2)	Correlation (R^2)
0.00	4.1	0.991	5.92	0.972
0.01	3.6	0.992	5.27	0.977
0.10	3.7	0.991	1.36	0.973
1.00	3.0	0.989	1.71	0.978
2.00	4.5	0.989	2.32	0.976

Table 3. Peak positions of the fluorescence bands of the curve fitted spectra of control and Cd-treated wheat seedlings. The measured LIF spectra were averaged and curve-fitted using GRAMS-32 software and peak positions of the existing bands were determined.

Cd concentration (mM)	488 nm excitation			355 nm excitation		
	Red band Peak (nm)	Far-red band Peak (nm)	blue band Peak (nm)	Green band Peak (nm)	Red band Peak (nm)	Far -red Peak (nm)
0.00	685.9	728.5	453.4	511.8	686.5	737.7
0.01	685.0	728.5	452.0	513.7	690.2	738.3
0.10	685.8	730.2	449.7	510.0	687.2	737.8
1.00	685.6	730.2	449.5	508.6	687.2	738.0
2.00	685.5	731.2	450.2	508.1	687.6	737.3

in Table 2. The peak positions of the LIF spectra of control leaves at 488 nm excitation were centred at 685.9 nm and 728.5 nm while 355 nm excited spectra consisted of four bands at around 453.4 nm, 511.8 nm, 686.5 nm and 737.7 nm (Table 3). It is evident from the results that red and far-red bands showed minimal shifting in the peak position while blue and green bands showed quite significant shifting upon Cd treatment. The shifting of the blue and green bands could be due to the interaction of Cd with various components of the cell walls, such as cinnamic acid, ferulic acid, quercitin, berberin, etc. (Lang et al., 1991).

The LIF spectra of the Cd-treated wheat seedlings showed increased values of fluorescence intensity of the red and far red bands as compared to the spectra of control seedlings in the case of 488 nm excited spectra. The increase in the intensity of the spectra could be correlated with the decrease in chlorophyll content and reduction of photosynthetic activity as observed by Rinderle and Lichtenthaler (1988) in DCMU treated *Phaseolus vulgaris* plants. The lower intensities obtained for 0.1 mM, 1.0 mM and 2.0 mM Cd-treated leaves compared to of 0.01 mM Cd-treated plants were probably due to the interaction of Cd with the reaction centres of the two photosystems. The higher concentrations of Cd (0.1, 1.0 and 2.0 mM) may induce alter-

ations in the thylakoid membranes and inhibit photochemical electron transport involving both reaction centers PS I and PS II. Hence, reduction in the intensity as well as in the general growth of the plants is obvious. At 355 nm excitation wave length, the radiation is absorbed by flavonol and cinnamic acid in the epidermal and mesophyll layers which fluoresce blue (450 nm) and green (520 nm) light. At 488 nm excitation, fluorescence comes directly from the outer mesophyll layers because of the strong absorption of the blue light by chlorophyll and carotenoids. Thus, a higher chlorophyll fluorescence yield was obtained. The difference in the intensity distribution pattern of the red and far-red bands of the spectra with blue and UV-A laser light excitation could be attributed to a change in the light penetration through the leaf on different energy transfer processes among pigments (Bornman and Vogelmann, 1988; Cen and Bornman, 1993). The intensity of the blue band decreased by 20.5% whereas the intensity of the green bands increased by 8.6% in 0.01 mM Cd-treated seedlings. The fluorescence intensity of the blue band increased with increasing Cd concentration. The intensity of the green band decreased after 0.1 mM Cd treatment while the intensity increased after 1.0 mM and 2.0 mM Cd treatment. Treatment with Cd may cause alterations in the amount of blue-green fluorescing substances in the cell walls resulting in an increase or decrease in blue green fluorescence intensity of the bands. The increase of blue-green fluorescence emission in Cd-treated *Phaseolus vulgaris* plants has been interpreted to be a result of the synthesis of secondary metabolites, such as ferulic and cumaric acids (Valcke et al., 1999). The accumulation of many metabolites in response to various stresses has been illustrated by Zang et al. (2000).

The Chl FIR has been established as a stress indicator and it increases with de-

Table 4. Normalized FIRs of spectra of control and Cd-treated wheat seedlings. The measured LIF spectra were averaged and processed through Gaussian curve fitting. The peak heights of the bands were determined and normalized with respect to the response curve of the used grating and detector system and FIRs were calculated.

Cd concentration (mM)	Chl FIR with 488 nm		Other FIR with 355 nm excitation				
	F685/ F730	F450/ F520	F450/ F685	F450/ F735	F520/ F685	F520/ F735	F685/ F735
0.00	0.83	2.16	8.29	5.75	3.83	2.66	0.69
0.01	0.98 (18.1)	1.58 (-26.9)	5.95 (-28.2)	2.91 (-49.4)	3.77 (-1.6)	1.84 (-30.8)	0.49 (-29.0)
0.10	0.83 (0.0)	3.46 (60.2)	14.92 (80.0)	7.46 (29.7)	4.31 (12.5)	2.15 (-19.2)	0.50 (-27.7)
1.00	0.82 (-1.2)	3.74 (73.1)	11.28 (36.1)	9.36 (62.8)	3.02 (-21.2)	2.50 (-6.0)	0.83 (20.3)
2.00	0.78 (-6.0)	4.01 (85.6)	17.16 (107.0)	8.99 (56.3)	4.28 (11.7)	2.23 (-16.2)	0.52 (-24.6)

* Values in parentheses represent the percent increase or decrease compared to the control.

creasing chlorophyll content and photosynthetic activity of the leaves. Table 4 represents the normalised Chl FIR as well as other FIRs resulting from both the 488 nm and 355 nm excited LIF spectra. The Chl FIR resulting from 488 nm excitation was 0.83 for the control sample and it increased by about 18 % in response to 0.01 mM Cd treatment while for 0.1 mM and 1.0 mM Cd-treated plants the Chl FIR was simi-

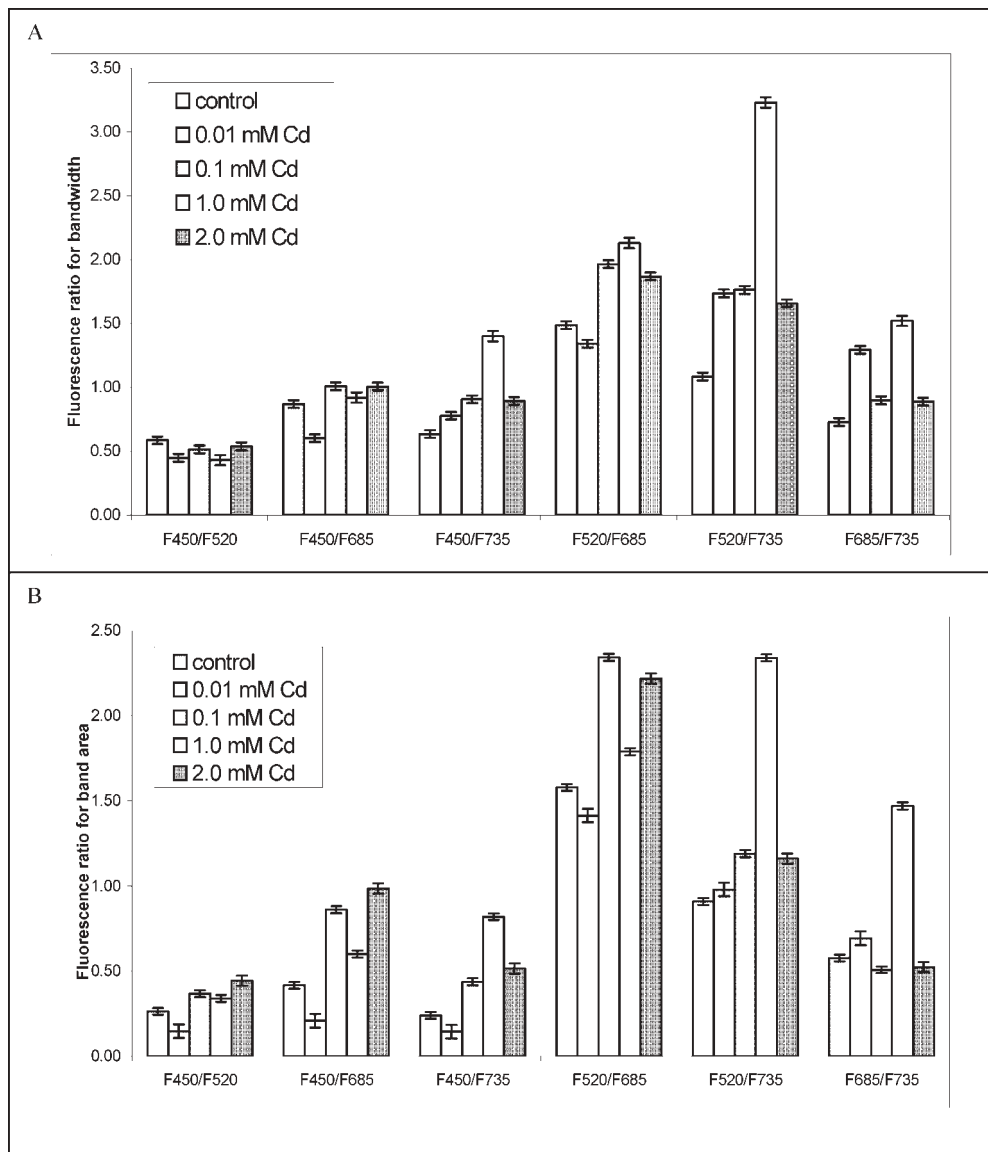

Fig. 5. Variations in the fluorescence ratios for the (A) bandwidth and (B) band area of 355 nm excited LIF spectra. Columns represent the mean value ($n=3$) and bars represent the standard error (SE).

lar to the control plants. In the case of 355 nm excited spectra, the Chl FIR decreased in 0.01 and 0.1 mM Cd-treated seedlings and increased by about 20% after treatment with 1.0 mM Cd. An increase in Chl FIR by 28% was found during the inhibition of photosynthetic electron transport by the herbicide diuron in *Phaseolus vulgaris* plants (Rinderle and Lichtenthaler, 1988). Our results showed that treatment with 2.0 mM Cd decreased the Chl FIR by about 6 % and 25 % as compared to controls at 488 nm and 355 nm excitation wave lengths, respectively. These results clearly demonstrated that higher concentrations of Cd inhibited severely the growth of the seedlings and decreased chlorophyll content, shoot length and fresh weight. The decrease in both Chl FIR and chlorophyll content could be correlated with the interaction of Cd with PSII reaction centre. The change in Chl FIR could also be due to the redox state of Q_A as Cd affects the electron transport /Calvin cycle, spill over changes, state changes and non photochemical quenching. The continuous increase in the FIR (F450/F520) values in 0.1 mM, 1.0 mM and 2.0 mM Cd-treated wheat seedlings may be due to the increase in the amount of blue fluorescing substances in the epidermis layer (Lang et al., 1992). The FIRs 450/F520, F450/F685, F450/F735, F520/F735 and F685/F735 decreased significantly after treatment with 0.01 mM Cd. The significantly higher values of the F450/F685 and F450/F735 ratios at higher concentrations of Cd could be an indication of a higher content of secondary metabolites, such as ferulic acid or cumaric acid which are involved in the biosynthesis of lignin, a component of cell walls (Valcke et al., 1999). The increases in synthesis accompanied by a stimulation of some enzymes of the Shikimate pathway have been observed during stress (Krause

Table 5. Rfd values for control and Cd-treated wheat seedlings. These values were calculated from the fluorescence induction kinetics curve, recorded up to five minutes at both red (685 nm) and far-red (735nm) of Chl fluorescence bands, using the method of Lichtenthaler.

Cd concentration (mM)	Rfd (685 nm)	Rfd (735 nm)
0.00	2.11	1.63
0.01	1.90 (-10.0)	1.03 (-36.8)
0.10	1.39 (-34.1)	0.96 (-41.1)
1.00	0.92 (-70.1)	0.77 (-52.8)
2.00	0.63 (-70.1)	0.60 (-63.2)

Each value is the mean of triplicate with SD less than 5%.

and Weis, 1992). The fluorescence ratios for the bandwidth and band area are presented in Fig. 5. The F450/F735 and F520/F735 ratios for the bandwidth together with the F520/F735 ratio for the band area showed similar patterns with increasing Cd concentration. On the other hand, the highest concentration of Cd applied (2.0 mM) was found to decrease the above ratios.

Fluorescence induction kinetics

The fluorescence induction kinetics measured on pre-darkened leaves consists of a fast fluorescence rise to a maximum intensity level (F_m) followed by a slow fluorescence decay (F_d) and a steady-state level (F_s). The fluorescence decrease ratio ($R_{fd} = F_d/F_s$) is a measure of photosynthetic capacity of a leaf (Lichtenthaler et al., 1986; Strasser, 1986) and the full potential capacity of a leaf may depend on the water status and the degree of stomata opening. R_{fd} values are known as a plant vitality index which declines steadily with increasing stress (Lichtenthaler, 1988). The R_{fd} values decline steadily with increasing Cd stress at both wavelengths and they were always higher for the Cd-treated seedlings in the 685 nm region than those measured in the 735 nm region (Table 5). Lichtenthaler (1988) has observed a similar decrease in the R_{fd} value at 690 nm and 730 nm during water stress induced by abscission of maple leaves (*Acer platanoides*) or spruce needles (*Picea omorika*). A decrease in the R_{fd} values at different Cd concentrations could be related to a decrease in the photosynthetic pigments as well as a damage caused to the photosynthetic apparatus. This result suggests also a reduced rate of CO₂ fixation caused by Cd which could be due to stomata closure and interaction of Cd with Calvin cycle enzymes (Weigel, 1985).

CONCLUSION

The spectral behaviour of the measured fluorescence bands depended mainly on the absorption properties of the leaves. The results presented here indicate that Chl FIR together with the other FIRs can give a lot of information regarding the physiological status of a leaf. The fluorescence signature of 488 nm and 355 nm laser light, plant vitality index calculated from fluorescence induction kinetics and the pigment data analysis revealed that even 0.01 mM Cd was harmful to the growth of the wheat seedlings. The lidar remote sensing of fluorescence signature of terrestrial vegetation can be useful for evaluation of plant health. However, the plant vitality index, calculated from fluorescence induction kinetics, seems to provide more accurate information regarding the state of plant health. On the other hand, it is not suited for remote sensing because induction kinetics requires longer measurement time and plants must be dark-adapted. The measured LIF could be processed by a curve-fit-

ting procedure using a linear combination of Gaussian spectral function to assist observation of the shift in the band peaks position and determination of the FIRs.

Acknowledgements: We are thankful to ISRO, Bangalore for financial assistance, to M.N.Saha centre of Space Studies, IIDS, Nehru Science Centre, Allahabad University, Allahabad and Dr. S. M. Prasad, Department of Botany, Allahabad University for providing facilities for cultivation of plants and determination of pigment content.

References

- Arnon, D. I., 1949. Copper enzymes in isolated chloroplasts; Polyphenoxidase in *Beta vulgaris*. *Plant Physiol.*, 24, 1-15.
- Babani, F., H. K. Lichtenthaler, 1996. Light-induced and age-dependent development of chloroplasts in etiolated barley leaves as visualized by determination of photosynthetic pigments, CO₂ assimilation rates and different kinds of chlorophyll fluorescence ratios. *J. Plant Physiol.*, 148, 555-566.
- Baryla, A., P. Carrier, F. Franck, C. Coulomb, C. Sahut, M. Havaux, 2001. Leaf chlorosis in oilseed rape plants (*Brassica napus*) grown on cadmium-polluted soil: causes and consequences for photosynthesis and growth. *Planta*, 212, 696-709.
- Bazzaz, F. A., G. I. Rolfe, R. W. Carlson, 1974. Effect of cadmium on photosynthesis and transpiration of excised leaves of corn and sunflower. *Physiol. Plant.*, 32, 373-377.
- Bazzaz, M. B., Govindjee, 1974. Effects of Cadmium Nitrate on Spectral Characteristics and Light Reactions of Chloroplasts. *Environ. Let.*, 6, 1-12.
- Bornman, J. F., T. C. Vogelmann, 1988. Penetration of blue and UV radiation measured by fibre optics in spruce and fir needles. *Physiol. Plant.*, 72, 699-705.
- Buschmann, C., G. Langsdorf, H. K. Lichtenthaler, 2000. Imaging of blue, green, and red fluorescence emission of plants: An overview. *Photosynthetica*, 38(4), 483-491.
- Carlson, R. W., F. A. Bazzaz and G. L. Rolfe, 1975. The effects of heavy metals on plants II. Net photosynthesis and transpiration of whole corn and sunflower plants treated with Pb, Cd, Ni, Ti. *Environ. Res.*, 10, 113-120.
- Cen, Y. P., J. F. Bornman, 1993. The effect of exposure to enhance UV-B radiation on the penetration of monochromatic and polychromatic UV-B radiation in leaves of *Brassica napus*. *Physiol.Plant.*, 87, 249-255.
- Chappelle, E. W., J. E. McMurtrey, F. M. Wood, W. W. Newcomb, 1984. Laser induced fluorescence of green plants. 2.LIF caused by nutrient deficiencies in corn. *Appl. Opt.*, 23, 139-142.
- Gopal, R., K. B. Mishra, M. Zeeshan, S. M. Prasad, M. M. Joshi, 2000. Laser induced chlorophyll fluorescence spectra of mung plants growing under nickel stress. *Current Science*, 83, 880-884.
- Goodwin, T. W., 1954. Carotenoids. In: Peach K. and Tracey M. W. (ed.) *Handbook of plant analysis*. Springer- Verlag, III, 272-311.
- Haghiri, F., 1973. Cadmium uptake by plants. *J Environ Quality*, 2, 93-96.

- Han, J. R., W. j. Zhao, Y. Y. Gao, J. M. Yuan, 2005. Effect of oxidative stress and exogenous β -carotene on sclerotial differentiation and carotenoid yield of *Penicillium* sp. PT95. Lett. In Appl. Microbiol., 40, 412-417.
- Johnson, G. A., S. V. Mantha, T. A. Day, 2000. A spectrofluorometric survey of UV - induced blue green fluorescence in foliage of 35 species. J. Plant Physiol., 156, 242-252.
- Kastori, R., M. Petrovic, N. Petrovic, 1992. Effect of Excess Lead, Cadmium, Copper, and Zinc on Water Relations in Sunflowers. J. Plant Nutr., 15, 2427-2439.
- Krause, G.H., E. Weis, 1991. Chlorophyll fluorescence and photosynthesis: the basics. Annu. Rev. Plant Physiol. Plant Mol. Biol., 42, 313 – 349.
- Krupa, Z., T. Baszynski, 1995. Some aspects of heavy metals toxicity towards photosynthetic apparatus – direct and indirect effects on light and dark reactions. Acta Physiol. Plant., 17, 177-190.
- Lang M., F. Stober, H. K. Lichtenthaler, 1991. Fluorescence emission spectra of plant leaves and plant constituents. Radiat. Environ. Biophys., 30, 333-347.
- Lang, M., P. Siffel, Z. Braunova, H. K. Lichtenthaler, 1992. Investigation of blue green fluorescence emission of plants leaves. Botanica Acta, 105, 435 - 440.
- Larsoon, E. H., J. F. Bornmann, H. Asp, 1998. Influence of UV-B radiation and Cd²⁺ on chlorophyll fluorescence, growth and nutrient content in *Brassica napus*. J. Exp. Bot., 323, 1031-1039.
- Lichtenthaler, H. K., C. Buschmann, U. Rinderle, G. Schmuck, 1986. Application of chlorophyll fluorescence in ecophysiology. Radiat. Environ. Biophys., 25, 297-308.
- Lichtenthaler, H. K. (ed.), 1988. In: Applications of chlorophyll fluorescence in photosynthesis Research, Stress Physiology, Hydrobiology and remote Sensing, Kluwer Academic Publishers, 129-142.
- Lichtenthaler, H. K., J. Schweiger, 1998. Cell wall bound ferulic acid, the major substance of the blue-green fluorescence emission of plant. J. Plant Physiol., 152, 272-282.
- Lichtenthaler, H. K., M. Lang, F. Stober, 1991, Proc Internat Colloq Phys Measurement and signatures in remote sensing, Courchevel, 91, 727-730.
- Porra, R. J., 2002. The chequered history of the development and use of simultaneous equations for the accurate determination of chlorophylls *a* and *b*. Photos. Res., 73, 149-156.
- Rinderle, U., H. K. Lichtenthaler, 1988. The chlorophyll fluorescence ratio F690/F735 as a possible stress indicator. In: Lichtenthaler HK (ed.) Applications of chlorophyll fluorescence, Kluwer Academic Publishers, Dordrecht, 189-196.
- Schutzendubel, A., P. Schanz, T. Teichmann, K. Gross, R. Langenfeld-Heyser, D. Godbold, A. Polle, 2001. Cadmium-induced changes in antioxidative systems, hydrogen peroxide content, and differentiation in scots pine roots. Plant Physiol., 127, 887-898.
- Strasser R. J., 1986. Laser induced fluorescence of living plants and its application in environmental research. *Proc Int Geosci Remote Sens Symp (IGARSS)*, ESA Publication division, Noordwijk, 3, 1581.
- Stratton, P. S., C. D. Liebler, 1997. Determination of singlet oxygen- specific versus radical-mediated lipid peroxidation in photosensitized oxidation of lipid bilayers : Effect of β -carotene and α -tocopherol. Biochemistry, 36, 12911-12920.

- Stober, F., M. Lang, H. K. Lichtenthaler, 1994. Blue, green, and red fluorescence emission signatures of green, etiolated, and white leaves. *Remote Sense Environ.*, 47, 65-71.
- Subhash, N., C. N. Mohanan, 1997. Curve fit analysis of chlorophyll fluorescence spectra application to nutrient stress detection in sunflower. *Remote Sense Environ.*, 60, 347-356.
- Valcke, R., M. Ciscato, F. Heisel, J. Mische, M. Sowinska, 1999. Analysis of heavy metal stressed plants by fluorescence imaging. *Proceeding of SPIE Conference on Laser Radar Technology and applications IV*, 3707, 82 - 92.
- Weigel H. J., 1985. The effect of Cd^{2+} on photosynthetic reactions of mesophyll protoplasts. *Physiol. Plant.*, 63, 192-200.
- Zang, F., X. Li, C. Wang, Z. Shen, 2000. Effect of cadmium on autoxidation rate of tissue and inducing accumulation of free proline in seedling of Mung Bean. *J. Plant Nutr.*, 23(3), 357-368.

ANTISENESCENCE EFFECT OF 2-PYRIDYLUREAS WITH UN- AND CYCLIC- UREIDO GROUP

Petranka Yonova and Gergana Stoilkova*

Acad. M. Popov Institute of Plant Physiology, BAS, Acad. G. Bonchev Str., Bl. 21, 1113 Sofia, Bulgaria

Dedicated to the memory of Acad. E. Karanov

Received 24 November, 2005

Summary. The potential antisenescence effect of eight synthetic urea compounds was investigated in excised barley (*Hordeum vulgare* L.) leaves which were induced to senesce by incubation in complete darkness. The compounds having uncyclic ureido group showed higher chlorophyll retention activity than those with cyclic ureido group. Compounds 1, 6 and 4PU had long-term protecting effects on chlorophyll degradation whereas the effects of compounds 2 and 5 were short-term. These effects were mediated by increased H_2O_2 -scavenging enzyme activities. The chlorophyll retention activity of the more active compounds (1, 2, 5, 6, 8) was lower compared to the standard 4PU at the end of the third aging day. Treatment of leaf segments with compounds 1 and 8 resulted in an increased carotenoids content after 48 h. In addition, it was higher compared to the 4PU-treated leaf tissues. Our results provide information about the relationship between the antisenescence effect of synthetic urea compounds and the activity of some antioxidative enzymes. We suggest that the activities of the antioxidative enzymes as well as the balance between H_2O_2 -generating and H_2O_2 -scavenging enzymes are important parameters that could provide evidence about the senescence-retarding effect of the tested compounds. The structure - activity relationships for the screened compounds was also studied. The presence of unsubstituted 2-pyridyl ring and of 5-chloro- or (3,5-dichloro)-2-pyridyl ring contributed to the higher activity of the tested compounds.

Key words: antioxidative enzymes, barley leaf antisenescence bioassay, dark-induced senescence, stress-markers, ureas

* Corresponding author, e-mail: pyonova@yahoo.com

Abbreviations: AOS-active oxygen species, AsPO-ascorbate peroxidase, CAT-catalase, Chl-chlorophyll, FW-fresh weight, GPO-guaiacol peroxidase, SOD-superoxide dismutase, 4PU-N-phenyl-N'-(4-pyridyl)urea, THF-tetrahydrofuran

INTRODUCTION

Foliar senescence is a pre-programmed stage in the development of the plant and it is subjected to direct physiological and genetic control (Thomas and Stoddart, 1980; Leshem et al. 1986). Cytokinins constitute a major class of plant growth regulators which are known to retard the process of senescence including protein, nucleic acids, and chlorophyll degradation in excised leaf tissues (Sabater, 1985; Davies, 1987). Cytokinin activity possessed by at least four different classes of compounds: purines, modified purines, heterocyclic ureas (and amides) and aminopyrimidines has been reported (Matsubara, 1980). Among urea derivatives tested, N-phenyl-N'-(4-pyridyl)urea (4PU) exhibits strikingly high cytokinin activity comparable to 6-benzylaminopurine (BAP). Moreover, an electronegative chlorine atom introduced at the 2nd position of the pyridyl ring increases strongly the activity (4PU-30) (Isogai, 1981). It is well known that the 2-chloroethyl group, included as a substituent to biologically active substrates (carriers) attributes different physiological action (Белоусова и др. 1977). Thus, the growth regulating chemical EDU, N-[2-(2-oxo-1-imidazolidinyl)ethyl]-N'-phenylurea showed much higher effectiveness in arresting senescence and plant protection against ozone injury than kinetin (Lee and Chen, 1982; Miller et al. 1994), but it was not a protectant against UV-B damage in cucumber leaves (Krizek et al. 2001).

Compounds having other ring substituents, such as triazoles and imidazoles combined with ureido- or carbamoyl-groups, have been synthesized and evaluated as cytokinins and plant antisenesescence agents (Fawzi and Quebedeaux, 1976; Cavender et al. 1988).

Senescence is characterized by a cessation of photosynthesis, disintegration of organelle structures, intensive loss of chlorophyll and proteins, and dramatic increase in lipid peroxidation and membrane leakage (Buchanan-Wollaston, 1997). The changes in the photosynthetic parameters are found mainly for differentiated leaves and for longer periods of senescence. However, it has been shown (Ananieva et al., 2005) for intact zucchini cotyledons that the short term induced senescence (24 h dark treatment) does not result in any appreciable changes in the functional activity of PSII and the net photosynthetic rate. It is firmly established that lipid peroxidation is due mainly to the strong enhancement of active oxygen species (AOS) generation which takes place in plant tissues during the senescence process (Leshem, 1988; Nooden et al., 1997). However, plants possess enzymatic and nonen-

zymatic antioxidative defence systems providing adequate cellular protection against AOS.

Recently, volatile compounds, particularly heterocyclic flavor chemicals, have been found to protect lipids from oxidation (Macku and Shibamoto, 1991; Eiserich and Shibamoto, 1994). The antioxidative activity of these compounds (imidazoles, thiazoles, oxazoles, furanones and thiophenes) determined toward the oxidation of hexanal to hexanoic acid was not as strong as that of the known antioxidant α -tocopherol (Shaker et al., 1995). Krivenko et al. (2000) tested seven arylthioureas with alkyl, aryl and heterocyclic substituents as antioxidants. The results showed that the sterically hindered arylthioureas have the highest antioxidative activity. Darlington et al. (1996) found that the synthetic antioxidant Ambiol [2-methyl-4-(dimethylaminomethyl)-5-hydroxybenzimidazole dihydrochloride] applied by seed treatment of two dicotyledons increased their growth under drought conditions.

It could be expected that exogenously applied heterocyclic ureas/thioureas might be able to retain the senescence process probably due either to an inhibition of the oxidative degradation process or to stimulation of the antioxidative defence system.

Here, we studied the ability of eight 2-pyridylureas to delay senescence in excised barley leaves and the relationship between their antisenesescence and oxidant protection effects. In this respect, we determined the time-dependent changes in the contents of chlorophyll, carotenoids, hydrogen peroxide, malondialdehyde and in the activities of catalase, ascorbate- and guaiacol-peroxidases, and superoxide dismutase during senescence.

MATERIALS AND METHODS

Synthesis of chemicals

The method used to prepare N-(2-chloroethyl)-N'-(2-pyridyl)ureas is outlined in the following scheme:

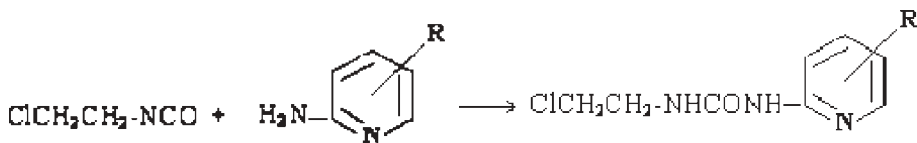

- | | |
|--------------|-----------------------------|
| 1 - R = H | 4 - R = 4,6-Me ₂ |
| 2 - R = 4-Me | 5 - R = 5-Cl |
| 3 - R = 5-Me | 6 - R = 3,5-Cl ₂ |

The compounds 1 - 3 were reported earlier (Vassilev et al., 1984) while compounds 4 - 6 are newly synthesized.

General procedure. The reaction was carried out in a medium of dichloromethane (20 ml for 0.01 mol 2-aminopyridines) with the addition of 5% mol excess of 2-chloroethylisocyanate by stirring in an ice-water bath for 1h. The reaction products crystallized quickly and were removed by filtration, washed with 3-5 ml of cooled ethanol and dried in a vacuum pump at room temperature. The crude products were purified by recrystallization from ethanol.

N-(2-chloroethyl)-N'-(4,6-dimethyl-2-pyridyl)urea (4): yield 98%, mp.112°C. Anal. Calcd for C₁₀H₁₄N₃OCl: C, 52.75; H, 6.15; N, 18.46. Found: C, 52.80; H, 6.13; N, 18.39.

N-(2-chloroethyl)-N'-(5-chloro-2-pyridyl)urea (5): yield 99%, mp.172°C. Anal. Calcd for C₈H₉N₃OCl₂: C, 41.03; H, 3.85; N, 17.95. Found: C, 41.20; H, 4.04; N, 17.81.

N-(2-chloroethyl)-N'-(3,5-dichloro-2-pyridyl)urea (6): yield 81%, mp.137°C. Anal. Calcd for C₈H₈N₃OCl₃: C, 35.75; H, 2.98; N, 15.64. Found: C, 35.62; H, 3.14; N, 15.68.

The second set of compounds, 1-(2'-pyridyl and 4'-methyl-2'-pyridyl)-2-oxoimidazolidines, was obtained by intramolecular N-alkylation of compounds 1 and 2 using a phase transfer catalyst - pulverized KOH THF as a solvent and triethylbenzylammonium chloride as a catalyst.

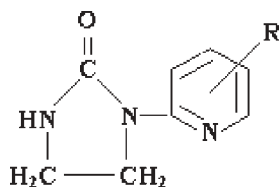

7 - R = H

8 - R = 4-Me

The preparation of compounds 7 and 8 has been previously described (Yonova and Stoilkova, 2005).

Barley leaf antisenesescence bioassay

Barley (*Hordeum vulgare* L. cv. Alfa) seeds were planted in wet vermiculite, placed in a growth chamber (24°C, 16-h days, 19°C night, relative humidity 50% and light intensity of 120 $\mu\text{mol}\cdot\text{m}^{-2}\cdot\text{s}^{-1}$ PFD), and watered three times a day with tap water. Ten 3-cm long leaf segments, cut from 7-day-old primary barley leaves starting 0.5 cm below the tip were placed in a Petri dish (10-cm i.d.) containing 5 ml test solution. The test solutions used were as follows: phosphate buffer containing 0.02% Tween-80 (1 mM KH₂PO₄ - Na₂HPO₄, pH 5.8, control), 1.0 and 0.1 mM solutions of the tested compounds (1 - 8) and 4PU used as a standard (9), prepared in the same buffer

with 0.02% Tween-80. The Petri dishes were kept in the dark at $24\pm 1^\circ\text{C}$. The leaf segments were taken at regular intervals (24, 48 and 72 h) for determination of chlorophyll, carotenoids, hydrogen peroxide and malondialdehyde levels as well as superoxide dismutase (SOD), catalase (CAT), ascorbate peroxidase (AsPO) and guaiacol peroxidase (GPO) activities.

Biochemical analyses

Fresh plant material (10 segments of 0.250g FW) was immediately extracted and assayed according to the appropriate methods listed below. The content of chlorophylls a, b and carotenoids was determined spectrophotometrically after extraction of 0.1 ml aliquots of buffer homogenate in 1.9 ml 80% (v/v) acetone at 4°C in the dark for 1 h and subsequent centrifugation at 4000g for 10 min. The optical density (OD) of the supernatants was read at 663, 645 and 460 nm, respectively (Mackinney, 1941). Hydrogen peroxide content was measured spectrophotometrically after reaction with 1 M KJ for 1 h in darkness and its amount was calculated using a standard curve (Alexieva et al., 2001). Lipid peroxidation was estimated based on determination of malondialdehyde content (MDA - a product of lipid peroxidation) using the thiobarbituric acid reaction (Dhindsa et al., 1981).

Enzyme analyses

Leaf segments (about 0.250g FW) were homogenized in 0.1 M K-phosphate buffer, pH 7.0, containing 1.0 mM $\text{Na}_2\text{-EDTA}$ and 1% (w/v) polyvinylpyrrolidone. The extracts were centrifuged at 14 000g for 30 min and the supernatant was used as a crude enzyme extract. All steps in the preparation of the enzyme extract were carried out at $0\text{-}4^\circ\text{C}$. Enzyme activities were determined spectrophotometrically at 25°C according to the following protocols: SOD (Beuchamp and Fridovich, 1971), CAT (Beers and Sizer, 1952), AsPO (Nakano and Asada, 1987) and GPO (Dias and Costa, 1983). Soluble protein content was determined by the method of Bradford (1976) using bovine serum albumin as a standard.

Statistical analysis

The data are presented as average values of at least 9 replicates, obtained from three independent experiments. The significance of differences was determined by the Student's t-test, and $P\leq 0.05$ and 0.01 were considered significant. The differences of variances were checked by Fisher's F - test.

RESULTS AND DISCUSSION

Pigment content and level of oxidative parameters

The effect of compounds 1 - 8 on chlorophyll and carotenoid contents is illustrated in Fig. 1 and 2. Among the compounds with unicyclic ureido group, compound 1 possessing an unsubstituted 2-pyridyl ring showed the highest chlorophyll retention activity since the chlorophyll content in the senescing leaf segments was higher compared to the control segments (36% at 0.1 mM and 49% at 1 mM after 48 and 72 h incubation, respectively). Compounds 2, 3 and 4 containing one or two CH₃ groups on the 2-pyridyl ring delayed the chlorophyll loss only after 24 h incubation (13 - 26% Chl over the control level). The 5-CH₃ isomer (3) reported by Vassilev et al. (1984) to possess high cytokinin-like activity in the *Amaranthus* bioassay at an optimum concentration of 0.1 mM showed slight activity in the barley leaf antisenesescence bioassay. Compound 5 with one chlorine atom on the 2-pyridyl ring retarded the chlorophyll loss in the aging leaf segments only during the first 24 h (20% and 37% at 0.1 and 1 mM, respectively) while the retarding effect of compound 6 with two chlorine atoms was higher compared with the control during the later aging periods (26% Chl at 0.1 mM and 39% Chl at 1 mM after 48 h incubation; 18% Chl at 0.1 mM and 23% Chl at 1 mM after 72 h incubation over the control).

Cyclization of the ureido group in the imidazolidinone ring (compounds 7 and 8)

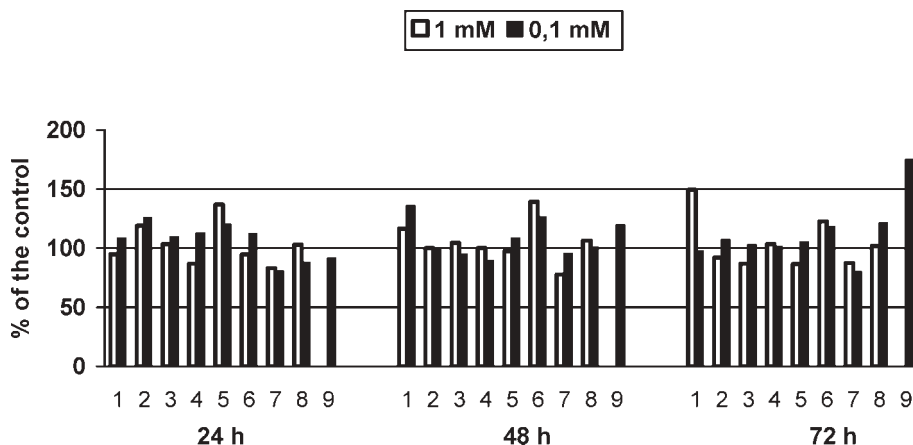

Fig. 1. Effect of compounds 1 - 8 and 4PU (9) on the time-dependent changes in **total chlorophyll** content during dark senescence of barley leaf segments floated on phosphate buffer (control) or on test compound solutions for 24, 48 and 72h. Data are expressed as percent of the control (the average value was 69.73 ± 1.19 , 47.0 ± 1.80 and 36.0 ± 1.23 $\mu\text{g Chl.segment}^{-1}$ at 24, 48 and 72h, respectively ($n=8$)). Chlorophyll content on day zero was 86.964 ± 1.29 $\mu\text{g Chl.segment}^{-1}$.

Variant means were significantly different ($p \leq 0.05$) from the control by the Fisher's exact test.

resulted in decreased chlorophyll retention activity. This effect was more pronounced after treatment with compound 7 when compared with compound 1. Compound 8 at 0.1 mM showed significant activity only after 72 h incubation (21% Chl over the control).

The chlorophyll retention activity of the more active compounds (1, 2, 4^{0.1}, 5, 6) was higher till the end of the second day and lower at the end of the third aging day in comparison with the standard 4PU (9) (0.1 mM). The activity of 4PU increased with senescence progression (75% Chl over the control at day 3).

In general, the time-course changes in carotenoids content in the treated leaf segments (Fig. 2) was similar to the chlorophyll content changes. Carotenoid content was significantly lower compared to the chlorophyll content during the respective senescing period in the case of compounds 1, 5, 6 applied at a concentration of 1 mM. The content of carotenoids in the compound 6-treated leaf segments increased even during the first 24 h and reached its maximum by the end of the third aging day (1 mM, 29% over the control at 72h) while the retarding effect of this compound on Chl degradation was optimal (39%) after 48h incubation. The compound 8-treated leaf segments had the highest carotenoids content (~50%) at day 2 of senescence. Treatment of leaf segments with compounds 1 and 8 resulted in an increased carotenoids content after 48 h which was higher compared with the 4PU-treated leaf tissues (28%).

Under dark senescence, the H₂O₂ level in the treated leaf segments was either

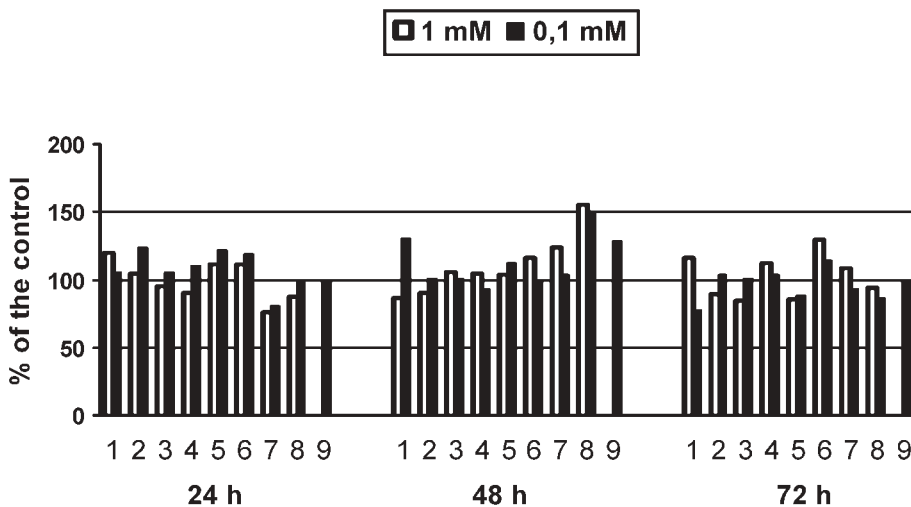

Fig. 2. Effect of compounds 1 – 8 and 4PU (9) on the time-dependent changes in **total carotenoids** content during dark senescence of barley leaf segments floated on phosphate buffer (control) or on test compound solutions for 24, 48 and 72h. Data are expressed as percent of the control (the average value was 4.44 ± 0.37 , 5.86 ± 0.43 and 4.86 ± 0.32 $\mu\text{g Carot. segment}^{-1}$ at 24, 48 and 72h, respectively ($n=8$)). Variant means were significantly different ($p \leq 0.05$) from the control by the Fisher's exact test.

similar or lower compared to the control. A relatively small increase in H_2O_2 content (10-27%) was observed in the 1, 2, 5, 6-treated leaf segments during different senescing periods (Fig. 3).

The test compounds 2 (0.1 mM), 3 (1 mM), 5 (1 mM), 6 (0.1 and 1 mM) and 8 (0.1 and 1 mM) caused an increase in MDA content of senescing leaf segments during the first 24 h (28-88%), followed by a decrease reaching the control levels. No decline was observed only in the compound 8 (1 mM)-treated segments during the whole senescing period (Fig. 4).

The levels of H_2O_2 and MDA in the 4PU-treated leaf segments were always below the control values during the whole period of senescence.

Antioxidant enzyme activities

The tested compounds 1 - 8 promoted strongly the specific catalase activity in the aging leaf segments (2- to 5-fold higher compared to the control). In all cases, CAT activity of the leaf segments treated with 1 mM of compounds 1 - 8 was higher than that of the 0.1 mM-treated tissues. CAT activity increased even during the first 24 h, reaching to the maximum value at 48 h (at 72 h for 4- and 7-treated tissues) and decreased during day 3 of senescence but still the values remained 1.5-2.8-fold higher than the controls (Fig. 6).

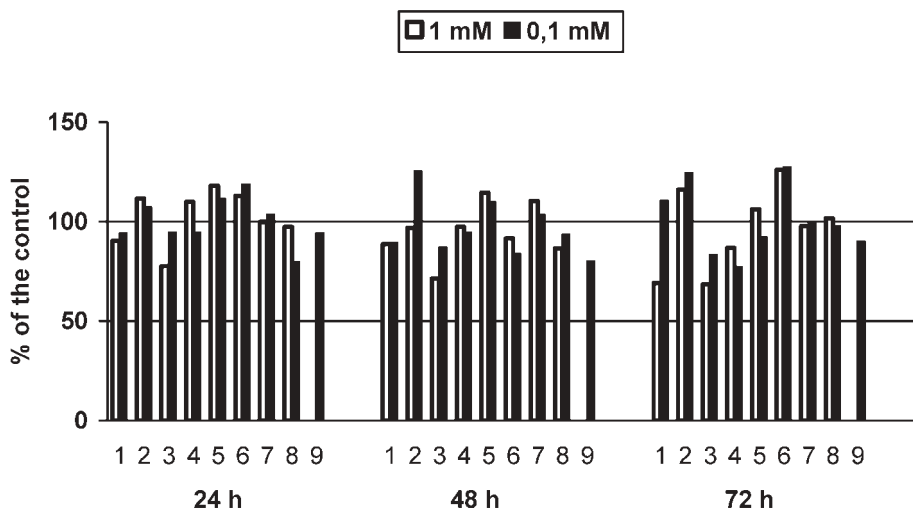

Fig. 3. Effect of compounds 1 - 8 and 4PU (9) on the time-dependent changes in H_2O_2 levels during dark senescence of barley leaf segments floated on phosphate buffer (control) or on test compound solutions for 24, 48 and 72h. Data are expressed as percent of the control (the average value was 23.72 ± 4.45 , 24.15 ± 4.79 and 17.87 ± 3.11 $\text{nmol H}_2\text{O}_2 \cdot \text{segment}^{-1}$ at 24, 48 and 72h, respectively ($n=8$)). Variant means were significantly different ($p \leq 0.05$) from the control by the Fisher's exact test.

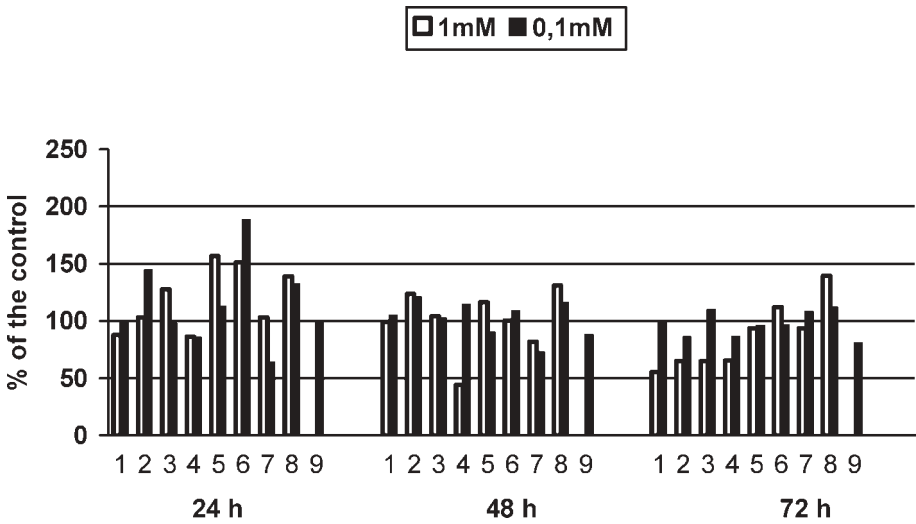

Fig. 4. Effect of compounds 1 – 8 and 4PU (9) on the time-dependent changes in MDA levels during dark senescence of barley leaf segments floated on phosphate buffer (control) or on test compound solutions for 24, 48 and 72h. Data are expressed as percent of the control (the average value was 1.41 ± 0.103 , 1.28 ± 0.098 and 1.14 ± 0.083 nmol MDA.segment⁻¹ at 24, 48 and 72h, respectively (n=8)). Variant means were significantly different ($p \leq 0.05$) from the control by the Fisher's exact test.

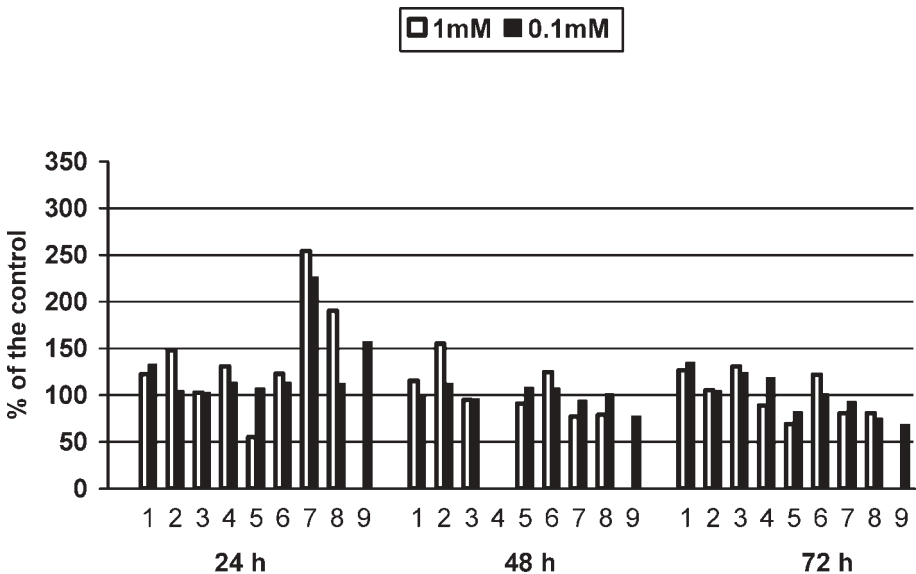

Fig. 5. Effect of compounds 1 – 8 and 4PU (9) on the time-dependent changes in SOD activity during dark senescence of barley leaf segments floated on phosphate buffer (control) or on test compound solutions for 24, 48 and 72h. Data are expressed as percent of the control (specific SOD activity was 13.2 ± 0.98 , 21.8 ± 2.72 and 33.0 ± 3.70 units.mg⁻¹protein at 24, 48 and 72h, respectively (n=4)). Variant means were significantly different ($p \leq 0.05$) from the control by the Fisher's exact test.

Compounds 1, 2, 8 and 4PU caused a short-term increase in GPO activity (about 20%) of aging leaf segments. Compound 6 (1 mM) increased significantly the GPO activity at day 2 (52% over the control). Longer exposure to compound 7 (1 mM) led to a moderate increase in the enzyme activity in the aging tissues (30% at days 2 and 3) (Fig. 7).

A high stimulation of AsPO activity (up to 2-fold) was observed in the aging leaf segments treated with unmodified- and Me-substituted-pyridyl derivatives (1, 2, 3, 4, 7 and 8) during the first 24 h. It decreased during the second 24 h and by the end of day 3 it was below the control value (with the exception of the compound 7-treated tissues). The aging leaf segments treated with Cl-substituted-pyridyl derivatives (5 and 6) showed a moderate increase (15-46%) in the enzyme activity during the whole period of senescence. The 5-treated tissues demonstrated higher AsPO activity at day 2 (31% and 46% at 0.1 and 1.0 mM, respectively), (Fig. 8).

The total SOD activity of the treated aging leaf segments increased during the first 24 h by about 30% after treatment with compounds 1, 4, 6 (1 mM) and over 50% with 2, 4PU, 7, 8 at 1 mM. Further, SOD activity decreased significantly whereas only the 2-treated segments preserved high activity at 48 h (55%). SOD activity was about 30% over the control in the 1, 3, 6 (1 mM)-treated leaf segments during the third day of the aging period. (Fig. 5)

The 4PU-treated leaf segments showed only a short-term increase in the activity of all antioxidative enzymes (SOD, AsPO, CAT, GPO).

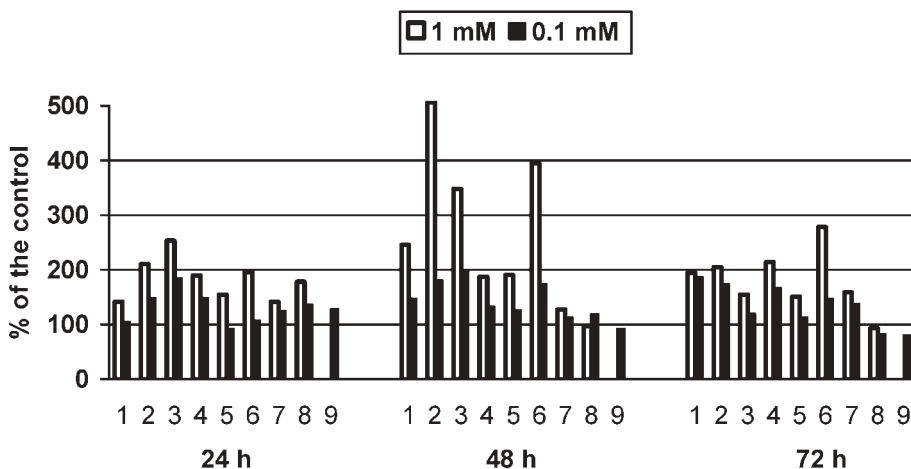

Fig. 6. Effect of compounds 1 – 8 and 4PU (9) on the time-dependent changes in CAT activity during dark senescence of barley leaf segments floated on phosphate buffer (control) or on test compound solutions for 24, 48 and 72h. Data are expressed as percent of the control (specific CAT activity was 118.0 ± 13.31 , 153.0 ± 13.92 and $233.7 \pm 17.24 \mu\text{mol}^1(\text{H}_2\text{O}_2)\cdot\text{min}^{-1}\cdot\text{mg}^{-1}\text{protein}$ at 24, 48 and 72h, respectively ($n=6$)).

Variant means were significantly different ($p \leq 0.05$) from the control by the Fisher's exact test.

Imbalance between SOD activity and H₂O₂-scavenging activity during dark senescence

Kanazawa et al. (2000) showed that the changes in the activity of the antioxidative enzymes during dark-induced senescence in cucumber cotyledons were generally different from those found during natural senescence. These authors found that the SOD/CAT ratio increased in the late stages of both natural and artificial senescence while SOD/AsPO and SOD/GPO ratios increased during artificial senescence but decreased during natural senescence. These findings suggest that the increase in the SOD/CAT ratio, but not the SOD/peroxidases ratios, could be used as a general index in senescent cells.

Thus, we further examined the changes in the activity ratio of SOD to H₂O₂-scavenging enzymes (catalase and peroxidases) (Table 1).

Our results showed that the activity ratios depended on the type and concentration of the compound tested as well as the stage of senescence. In most cases, the treated leaf segments showed much higher peroxisomal catalase activity and the SOD/CAT ratio was usually less than 1.00. GPO was activated to a lower extent than AsPO and the SOD/GPO ratio was higher than 1.00 during the whole senescence period. An increase in the SOD/AsPO ratio was observed only for the segments treated with *1* (1.48) and *3* (1.64) at day 3, and with 5-0.1 mM (1.55) at day 1.

Compounds *1* and 4PU showed a similar behaviour during the investigated period, but the antisenescence effect of 4PU was higher than that of compound *1* at the

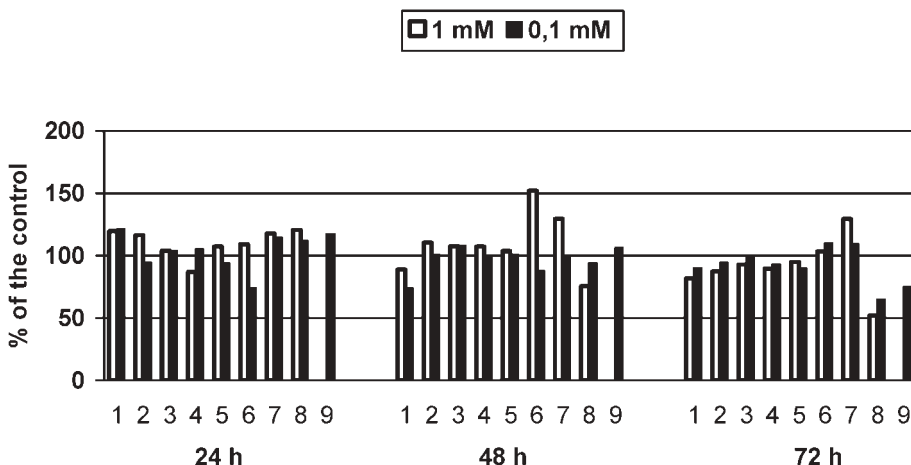

Fig. 7. Effect of compounds *1*–*8* and 4PU (*9*) on the time-dependent changes in GPO activity during dark senescence of barley leaf segments floated on phosphate buffer (control) or on test compound solutions for 24, 48 and 72h. Data are expressed as percent of the control (specific GPO activity of the control was 10.38 ± 1.37 , 18.39 ± 3.42 and 25.0 ± 3.51 $\mu\text{mol}\cdot\text{min}^{-1}\cdot\text{mg}^{-1}\cdot\text{protein}$ at 24, 48 and 72h, respectively ($n=8$)).

Variant means were significantly different ($p \leq 0.05$) from the control by the Fisher's exact test.

Table 1. Ratios of the activity of SOD relative to that of H₂O₂-scavenging enzyme during dark-induced senescence of barley leaf segments, 1 day, 2 days and 3 days after.

Variant /Conc. ^{a)}	SOD / CAT			SOD / AsPO			SOD / GPO		
	1 day	2 day	3 day	1 day	2 day	3 day	1 day	2 day	3 day
1 - 0.1	1.26	0.67	0.72	1.09	0.7	1.35	1.08	1.33	1.50
1.0	0.90	0.47	0.65	0.71	0.74	1.48	1.02	1.30	1.55
2 - 0.1	0.70	0.62	0.60	0.49	0.89	1.03	1.10	1.11	1.13
1.0	0.71	0.31	0.51	0.96	1.28	1.08	1.27	1.40	1.20
3 - 0.1	0.56	0.48	1.03	0.89	0.73	1.16	0.99	0.89	1.25
1.0	0.41	0.27	0.85	0.75	0.75	1.64	0.99	0.88	1.41
4 - 0.1	0.76	-	0.71	0.83	-	1.34	1.07	-	1.27
1.0	0.69	-	0.42	0.92	-	0.83	1.51	-	1.00
5 - 0.1	1.16	0.85	0.72	1.55	0.83	0.91	1.14	1.07	0.91
1.0	0.36	0.48	0.46	0.59	0.62	0.56	0.51	0.88	0.73
6 - 0.1	1.04	0.61	0.69	1.28	1.21	1.17	1.52	1.22	0.92
1.0	0.63	0.32	0.44	1.06	1.09	1.29	1.13	0.82	1.18
7 - 0.1	1.82	0.83	0.68	1.27	0.75	0.69	1.97	0.95	0.85
1.0	1.80	0.60	0.51	1.23	0.49	0.45	2.16	0.59	0.63
8 - 0.1	0.82	0.85	0.91	0.68	0.76	0.84	1.00	1.08	1.16
1.0	1.06	0.81	0.87	0.90	0.58	0.89	1.57	1.05	1.56
4PU ^{b)}	1.22	0.83	0.85	1.07	0.85	0.87	1.34	0.73	0.92

a) concentration of test compounds in mM; b) the concentration of 4PU is 0.1 mM.

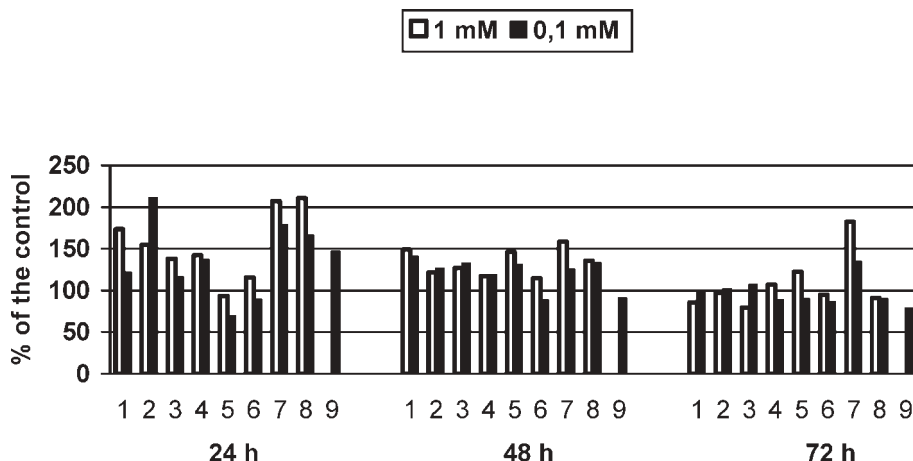

Fig. 8. Effect of compounds 1 – 8 and 4PU (9) on time-dependent changes in AsPO activity during dark senescence of barley leaf segments floated on phosphate buffer (control) or on test compound solutions for 24, 48 and 72h. Data are expressed as percent of the control (specific AsPO activity of the control was 1.37 ± 0.18 , 1.81 ± 0.25 and $2.76 \pm 0.22 \mu\text{mol}\cdot\text{min}^{-1}\cdot\text{mg}^{-1}\text{protein}$ at 24, 48 and 72h, respectively (n=8)).

Variant means were significantly different ($p \leq 0.05$) from the control by the Fisher's exact test.

end of day 3. They had equal SOD/CAT and SOD/AsPO activity ratios which decreased with progression of senescence. However, the third SOD/GPO activity ratio declined in the case of 4PU and increased for compound 1 during senescence. Probably, this may explain the different degree of the antisenescence effect of the two compounds.

The values of the three activity ratios for the 6-treated segments decreased up to day 2 and increased weakly during day 3 compared to day 2. Compound 6 manifested chlorophyll retention activity during 2 and 3 days with maximum activity at the end of day 2.

The three activity ratios for the compound 7-treated segments had significantly high values at day 1 - 1.82, 2.16 and 1.27 for SOD/CAT, SOD/GPO and SOD/AsPO ratios, respectively. It is possible that this imbalance during the onset of senescence may contribute to the lack of chlorophyll retention activity of compound 7.

In general, it could be suggested that chlorophyll retention activity correlates either with low values of the three activity ratios (< 1) or with the ability of the compounds to maintain the tissues in a reduced state. Therefore, not only SOD/CAT ratio could account for the chlorophyll retention activity of the different compounds. Other activity ratios (SOD/AsPO and SOD/GPO) could also contribute to this effect.

The lack of chlorophyll retention activity for compound 5 (1.0 mM) at days 2 and 3 of senescence was surprising since the values of the three activity ratios remained as low as at day 1. However, SOD activity was significantly inhibited during day 1 and thereby enhanced superoxide radicals can lead to high levels of lipid peroxidation. That is quite possible because the MDA content in compound 5-treated segments was high (57%). The activities of the three H_2O_2 -scavenging enzymes were strongly stimulated (over 2-fold higher than SOD activity) and as a result the values of SOD/CAT, SOD/GPO and SOD/AsPO ratios were around 0.5. Obviously, the balance between the antioxidative enzymes was disturbed in this case.

Therefore, we found that the activities of the antioxidative enzymes and the balance between them are important factors for demonstration of the senescence-retarding effect of the tested urea compounds. The most active compound 4PU, a well known cytokinin and used as a standard, was responsible for the balance between H_2O_2 -generating enzyme and H_2O_2 -scavenging enzymes in the senescing segments, since the values of the three activity ratios were approximately 0.85 during the second and the third aging days.

Structure – antisenescence activity relationship of compounds 1–8

Dark-induced senescence of detached leaves or leaf segments is well suited to examine the effect of synthetic compounds on senescence as well as to study various physiological and biochemical changes associated with senescence. Although these induction methods may cause effects similar to those occurring during natural senes-

cence, significant differences have been found with respect to gene expression (Weaver et al., 1998) or to a number of antioxidative enzymes (Kanazawa et al., 2000). In addition, the levels of the physiologically active cytokinin bases, ribosides and nucleotides decreased during both senescence processes. In contrast with natural senescence, the storage cytokinin O-glucosides decreased under dark conditions (Ananieva et al., 2004).

Increased carotenoid content is an important response of cells to senescence or stress. Carotenoids are natural antioxidants that act as defence agents to protect chlorophyll against the AOS damages.

The barley leaf antisenesescence bioassay is sensitive to structural variation of tested compounds. In fact, the same bioassay with wheat leaves has been used to develop quantitative structure-activity relationship for the antisenesescence activity of a number of N-(2-substituted-4-pyridinyl N-oxide)-N'-arylureas (Henrie et al., 1988) and 4,5-disubstituted imidazoles (Cavender et al., 1988).

We found that among the compounds displaying chlorophyll retention activity during different stages of senescence (1, 2, 5, 6, 8), four of them contain an unicyclic ureido group similar to the 4PU standard and one-cyclic ureido group.

The leaf segments treated with compounds 7 and 8 containing cyclic ureido group showed less catalase and higher peroxidases activities at days 2 and 3 of senescence than those treated with compounds 1- 6 containing unicyclic ureido group. In comparison with compounds 1- 6, treatment with compound 7 led to an increase in carotenoid content (by 24%) while compound 8 showed a significant increase (to 50%). Compound 1 increased carotenoid content by 31% only on the 2nd day. Compound 1 having an unsubstituted pyridine ring as well as compound 7 showed the highest antisenesescence effect whereas compound 7 had no activity. Therefore, the cyclization of the ureido group in an imidazolidinone ring modified the mode of the antisenesescence action compared to that of the compounds with unicyclic ureido group.

Among compounds 2, 3 and 4, possessing one or two CH₃ groups (an electron-donating group), the most active member of this series was the 4-methyl isomer (2). The latter had a short-term protecting effect on chlorophyll degradation in the senescent segments. This compound caused a moderate increase in carotenoids content (23%) and a higher increase in CAT and especially AsPO activities on day 1 of senescence.

Both compounds 5 and 6, containing one or two electron-withdrawing Cl atoms on the pyridine ring were the most active compounds among all tested compounds. Compound 6 with two Cl atoms had a long-term protecting effect on chlorophyll degradation while compound 5 with one Cl atom showed a short-term effect. Carotenoids content in senescing segments exceeded the control by 29% at day 3 upon compound 6-treatment, and by 21% at day 1 in the case of compound 5-treatment. The onset of senescence in the compound 5- and compound 6-treated segments was accompanied by a slight increase in H₂O₂ content and a significant increase in MDA

levels. Catalase activity was 3-fold higher and peroxidases activities were 2-fold higher than the SOD activity in the compound 5-treated segments on the first day. Higher H_2O_2 -scavenging activity was also observed in the compound 6-treated segments - catalase activity increased 3-fold compared to SOD activity while the peroxidase activity balanced the SOD activity after day 1. Evidently, the highly activated state of the H_2O_2 -scavenging enzymes contributed to the elimination of the consequences of the high extent of lipid peroxidation (51-57% over the control) occurring in the tissues during day 1 of senescence.

Our results indicated that the presence of CH_3 group(s) (compounds 2, 3, 4), the steric size of which is considered to be similar to that of a Cl atom (compounds 5, 6) did not provide the same level of antisenescence activity. A similar trend was found for the herbicidal activity of 4-substituted 4-oxazolin-2-one compounds (Kudo et al., 1998).

The high antisenescence effect of 4PU could be accounted for by its cytokinin activity. The exogenous cytokinin can probably compensate the declined levels of the endogenous physiologically active cytokinins in senescing tissues. The cytokinin-like activity demonstrated by compound 1 in this and other cytokinin bioassays (Vassilev et al., 1984) suggests that compounds 1- 8 represent a new class of cytokinin mimics.

CONCLUSIONS

The results presented here, indicated that the response of senescing leaf tissues was differently affected by the tested compounds. Compounds 1, 6 and 4PU had a long-term protecting effect on chlorophyll degradation whereas compounds 2 and 5 demonstrated a short-term effect. In addition, compound 8 showed activity only on day 3. This effect was mediated by strongly increased H_2O_2 -scavenging enzymes activities, the peroxisomal catalase activity being mainly affected. The cyclization of ureido group in an imidazolidinone ring modified the level and mode of antisenescence action compared to compounds with an uncyclic ureido group. It is difficult for us to explain the mechanism of the antisenescence action of the tested compounds since the cellular changes associated with senescence are a more complex situation that is not completely understood.

Acknowledgments: This study was partially supported by PISA / 2005-2007 project. We are grateful to Mrs. S.Samurova (Department of Chemistry, University of Sofia, Bulgaria) for providing CHN-analyses data.

References

- Белоусова А. К., Н. Н. Блохин, В. И. Борисов, Г. Ф. Гаузе, 1977. Химиотерапия злокачественных опухолей. Медицина, Москва,
- Alexieva V., I. Sergiev, S. Mapelli, E. Karanov, 2001. The effect of drought and ultraviolet radiation on growth and stress markers in pea and wheat. *Plant, Cell and Environ.*, 24, 1337-1344.
- Ananieva, K., J. Malbeck, M. Kaminek, J. v. Staden, 2004. Changes in endogenous cytokinin levels in cotyledons of *Cucurbita pepo* (zucchini) during natural and dark-induced senescence. *Physiol. Plant.*, 122, 133-142.
- Ananieva, K., K. Georgieva, N. Tzvetkova, S. Petkova, E.D. Ananiev, 2005. Specific effects of darkness and MeJA treatment on senescence related photosynthetic parameters in intact *Cucurbita pepo* L. (zucchini) cotyledons. *Compt. Rend. Acad. bulg. Sci.*, 58 (12), 1433-1438.
- Beauchamp C. H., I. Fridovich, 1971. Superoxide dismutase: improved assays and an assay applicable to acrylamide gels. *Anal. Biochem.*, 44, 276-287.
- Beers R. F., I.W. Sizer, 1952. A spectrophotometric method for measuring breakdown of hydrogen peroxide by catalase. *J. Biol. Chem.*, 195, 133-140.
- Bradford M. M., 1976. A rapid and sensitive method for the quantitation of microgram quantities of protein utilizing the principle of protein-dye binding. *Anal. Biochem.* 72, 248-254.
- Buchanan-Wollaston, V., 1997. The molecular biology of leaf senescence. *J. Exp. Bot.*, 48, 181-199.
- Cavender P. L., C. M. Green, S. B. Mack, 1988. Antisenescence activity of 4,5-disubstituted imidazoles: new cytokinin mimics. *J. Agr. Food Chem.* 36, 1076-1079.
- Darlington, A., K. Vishnevetskaia, T.J. Blake, 1996. Growth enhancement and antitranspirant activity following seed treatment with a derivative of 5-hydroxybenzimidazole (Ambiol) in four drought-stressed agricultural species. *Physiol. Plant.*, 97, 217-222.
- Davies P. J., 1987. *Plant hormones and their role in plant growth and development.* Kluwer, Boston, 76-93.
- Dhindsa R.S., P. Plumb-Dhindsa, T.A. Thorpe, 1981. Leaf Senescence: Correlated with increased levels of membrane permeability and lipid peroxidation, and decreased levels of superoxide dismutase and catalase. *J. Exp. Bot.*, 32 (126), 93-101.
- Dias, A., M. Costa, 1983. Effect of low salt concentration on nitrate reductase and peroxidase of sugar beet leaves. *J. Exp. Bot.*, 34, 537-543.
- Eiserich J. P., T. Shibamoto, 1994. Antioxidative activity of volatile heterocyclic compounds. *J. Agric. Food Chem.*, 42, 1060-1063.
- Fawzi M. M., B. I. Quebedeaux, 1976. Ureidotriazoles as cytokinins and plant antisenescence agents. *Chem. Abstr.* 84, P 13526k.
- Henrie II, R.N., C.M. Green, W.H. Yeager, T.F. Ball III, 1988. Activity optimization of pyridinyl N-oxide urea cytokinin mimics. *J. Agric. Food Chem.*, 36, 626-633.

- Isogai Yo, 1981. Cytokinin activities of N-phenyl-N'-(4-pyridyl)ureas. In: Metabolism and molecular activities of cytokinins (Eds. J. Guern, C. Peaud-Lenoel), Springer Verlag, Berlin-Heidelberg-New York, 115-128.
- Kanazawa S., S. Sano, T. Koshiba, T. Ushimaru, 2000. Changes in antioxidative enzymes in cucumber cotyledons during natural senescence: comparison with those during dark-induced senescence. *Physiol. Plantarum* 109, 211-216.
- Krivenko, L. V., E. N. Cherezova, N. A. Mukmeneva, 2000. Thioureas in reactions of inhibition of the oxidation of organic substrates. *Zh. Prikl. Khim.*, 73, 1193-1197.
- Krizek, D. T., E. M. Middleton, R. K. Sandhu, M. S. Kim, 2001. Evaluating UV-B effects and EDU protection in cucumber leaves using fluorescence images and fluorescence emission spectra. *J. Plant Physiol.*, 158, 41-53.
- Kudo, N., M. Taniguchi, S. Furuta, K. Sato, T. Endo, T. Honma, 1998. Synthesis and herbicidal activities of 4-substituted 3-aryl-5-tert-butyl-4-oxazolin-2-ones. *J. Agric. Food Chem.*, 46, 5305-5312.
- Lee E. H., C. M. Chen, 1982. Studies on the mechanisms of ozone tolerance: cytokinin-like activity of N-[2-(2-oxo-1-imidazolidinyl)ethyl]-N'-phenylurea, a compound protecting against ozone injury. *Physiol. Plant.* 56, 486-491.
- Leshem Y. Y., A. H. Halevy, C. Frenkel, 1986. Plant senescence. In: Processes and control of plant senescence (Eds. Y. Y. Leshem, A. H. Halevy, C. Frenkel), Elsevier, Amsterdam, 3-20.
- Leshem, Y. Y., 1988. Plant senescence processes and free radicals. *Free Radical Biol. Med.*, 5, 39-49.
- Mackinney G., 1941. Absorption of light by chlorophyll solutions. *J. Biol. Chem.*, 140, 315-322.
- Macku, C., T. Shibamoto, 1991. Volatile antioxidants produced from heated corn oil/glycine model system. *J. Agric. Food Chem.*, 39, 1990-1993.
- Matsubara S., 1980. Structure - activity relationships of cytokinins. *Phytochemistry* 19, 2239-2253.
- Miller, J.E., W.A. Pursley, A.S. Heagle, 1994. Effects of ethylenediurea on snap bean at a range of ozone concentrations. *J. Environ. Qual.*, 23, 1082-1089.
- Nakano Y., K. Asada, 1987. Purification of ascorbate peroxidase in spinach chloroplasts, its inactivation in ascorbate depleted medium and reactivation by monodehydroascorbate radical. *Plant Cell Physiol.*, 28, 131-140.
- Nooden L.D., J.J. Guiamet, I. John, 1997. Senescence mechanisms. *Physiol. Plant.*, 101, 746-753.
- Sabater B., 1985. Hormonal regulation of senescence. In: Hormonal regulation of plant growth and development (Ed. S. S. Purohit), Martinus Nijhoff/Dr. W. Junk Publishers: Boston, 169-217.
- Shaker, E.S., M.A. Ghazy, T. Shibamoto, 1995. Antioxidative activity of volatile browning reaction products and related compounds in a hexanal/hexanoic acid system. *J. Agric. Food Chem.*, 43, 1017-1022.
- Thomas H., J. L. Stoddart, 1980. Leaf senescence. *Annu. Rev. Plant Physiol.*, 31, 83-111.

- Vassilev, G. N., P. A. Yonova, V. I. Mihailov, Z. D. Raikov, 1984. Synthesis and biological activity of certain N-(2-chloroethyl)-N'-pyridyl and N'-methylpyridylureas. *Compt. rend. Acad. bulg. Sci.*, 37, No 6, 811-814.
- Weaver, L.M., S. Gan, B. Quirino, R.M. Amasino, 1998. A comparison of the expression patterns of several senescence-associated genes in response to stress and hormone treatments. *Plant Mol. Biol.*, 37, 455-469.
- Yonova P., G. Stoilkova, 2005. Synthesis and plant growth regulating activity of pyridyl-imidazolidinone compounds. *Compt. rend. Acad. bulg. Sci.*, 58, No 5, 595-600.

INFLUENCE OF LIGHT INTENSITY ON GROWTH AND CROP PRODUCTIVITY OF *VANILLA PLANIFOLIA* ANDR.

Jos Puthur

Post Graduate and Research Department of Botany, St. Thomas College, Pala, Arunapuram – 686 574 Kottayam, Kerala, India

Received 15 August 2005

Summary. To study the influence of light on growth and yield of *Vanilla* plants, 3 plots were marked in a vanillary, receiving sunlight with intensities varying between 300-1500 $\mu\text{E m}^{-2}\text{s}^{-1}$. Our results showed that photosynthesis was effective in *Vanilla* plants growing at sunlight of 300-800 $\mu\text{E m}^{-2}\text{s}^{-1}$ whereas only plants receiving 600-800 $\mu\text{E m}^{-2}\text{s}^{-1}$ sunlight were able to effectively partition the accumulated carbon into fruiting structures. Therefore, concerning productivity, light conditions of 600-800 $\mu\text{E m}^{-2}\text{s}^{-1}$ were most favoured while 300-600 $\mu\text{E m}^{-2}\text{s}^{-1}$ sunlight conditions were found to favour vegetative growth. Sunlight above 800 $\mu\text{E m}^{-2}\text{s}^{-1}$ affected productivity negatively. It was observed that proline as well as carotenoids accumulated in *Vanilla* plants with increasing light intensities. However, the protective mechanisms against the photodestructive high light were not sufficient to protect *Vanilla* plants from the photoinhibitory damage. This was clearly manifested by the high levels of lipid peroxidation as judged by the malondialdehyde (MDA) levels, low chlorophyll content, low oxygen evolution rate and low productivity in plants exposed to sunlight above 800 $\mu\text{E m}^{-2}\text{s}^{-1}$. These results confirm that shade plants do not have a well-developed mechanism to counteract the after-effects of photoinhibition.

Keywords: crop productivity, growth, light intensity, photosynthesis, *Vanilla planifolia*.

* Corresponding author, e-mail: jtputhur@rediffmail.com

INTRODUCTION

Orchids, the members of the family Orchidaceae are highly favoured ornamentals from time immemorial. Perhaps the only orchid which is of economic value other than as an ornamental is the Central American taxon *Vanilla planifolia* Andr. (Syn. *Vanilla fragrans*, Ames), the source of commercial vanillin. *Vanilla* is a tropical terrestrial genus of climbing orchids. The principal commercial source of vanillin ($C_8H_8O_3$) is the beans of *Vanilla planifolia* (Purseglove et al., 1981).

The efforts to propagate and popularize *Vanilla* cultivation in India have resulted in a large number of farmers taking it up. *Vanilla* was introduced in India as early as 1835. Recently, the area of *Vanilla* cultivation in India has been reported to be increasing very quickly to 1600 hectares due to the high market price of the beans and the sudden fall in the prices of other spices and plantation crops. During 2001- 2002 the total production of *Vanilla* beans in India was about 60 t³ (Sudharshan and John, 2003).

Being a new crop, the cultivation of *Vanilla* faces a number of constraints for development. There are some specific bottlenecks such as a narrow germplasm base, inadequate research, a developing package of practices, diseases etc. (Shanmugavelu et al., 2002). Besides the problems mentioned above, the optimal shade conditions for effective productivity in *Vanilla* warrants a thorough investigation. A shade provided less than that required can affect the productivity by causing more light to be incident on the plant and by bringing about photoinhibitory effects that harm the metabolic process of the system (Vyas, 2004). A shade well above that required can also reduce the productivity, since the photosynthetic mechanism of the system does not work to its full efficiency (Shivasankara et al., 2000). Therefore, it is necessary to investigate the optimal light conditions that can maximize productivity. As far as improvement in crop yield is concerned, the aspect of solar energy utilization in photosynthesis is considered to be an area of high potential for further research (Natu and Ghildiyal, 2005)

Variations in light intensity have diverse effects on leaf area development, plant growth and yield (Saini and Nanda, 1986; Singh, 1994; Vyas et al., 1996; Vyas and Nein, 1999). High light is capable of causing stress to the plant and of inducing the production of reactive oxygen species and free radicals which are known to break DNA, destroy the functions of proteins and are also responsible for lipid peroxidation (Alia et al., 2002; Arora et al., 2002). *Vanilla*, which falls into the category of shade-loving plants, shows all characteristic features exhibited by this group of plants. High intensity light falling on shade-loving plants can cause inactivation of reaction centers accompanied by an inhibition of the electron transport through photosystems. Besides, it affects also the activities of the carbon cycle enzymes (Netto et al., 2005).

Plants have evolved diverse strategies for acclimatization and avoidance to cope with adverse environmental conditions. These include the accumulation of compatible solutes like glycine, betaine, proline, mannitol etc. Proline has been shown to protect plants against singlet oxygen and free radical-induced damages (Puthur et al., 1996; Netto et al., 2005). Due to its action as a singlet oxygen quencher and scavenger of free hydroxyl radicals, proline is able to stabilize proteins, DNA and membranes (Alia et al., 2002).

The present study was undertaken with the main objectives to correlate light utility and crop productivity in *Vanilla planifolia* and investigate the effect of high light on its physiological status.

MATERIALS AND METHODS

Plant material

Vanilla planifolia is an orchid species. The plant has long, green, succulent, simple or branched stems producing alternate leaves and nodal aerial roots which cling to tree trunks and other supports.

Two vanillaries at different locations in the Kottayam district of Kerala State, India, were selected for the study. In each vanillary, three plots were selected and the sunlight was regulated by spreading different layers of shade nets 2 feet above the plants. The light intensities between 11.30 am to 12.00 am in the three plots were 300-600, 600-800, and above 800 $\mu\text{E m}^{-2} \text{s}^{-1}$, respectively. In each plot, 12 plants of equal and appropriate growth features were selected and labeled. Various parameters such as fruiting, number of inflorescence per plant, number of flowers per inflorescence and number of fruits per plant were recorded for further analyses. Leaves were collected (6th leaf from the apex) for determination of leaf area, fresh and dry weight. The plants selected for the study were 6 years old.

Growth Parameters

Leaf area, leaf fresh weight and leaf dry matter were calculated according to the formulae described by Evans (1972).

Determination of the photosynthetic pigments

For determination of total chlorophyll (chl) and carotenoid pigment content leaf samples were homogenized in 80% chilled acetone, centrifuged at 12000g for 10 min (4^o C) according to Arnon (1949) and the supernatant was used for quantification of the pigments (McKinney, 1941).

Analyses of oxygen evolution

Healthy leaves were collected from plants acclimatized to all three intensities of sunlight. The collected leaves were in labelled petriplates containing moisture and brought to the laboratory for analyses. Fresh leaf discs of 10 cm² were punched under water. The surface of the leaf discs were quickly wiped with a blotting paper and then the discs were immediately transferred to a leaf disc chamber of oxygen electrode (LD/3, Hansatech, UK). The changes in the concentration of gaseous oxygen within the chamber were monitored (Delieu and Walker, 1983). The leaf discs were first acclimatized in the dark for 5 minutes and then exposed to light intensity of 400 $\mu\text{E m}^{-2}\text{s}^{-1}$ using LED source (LH36, Hansatech, UK). The photosynthetic oxygen evolution was measured at 25^o C. To avoid any CO₂ limitation for photosynthesis, 100 μmol of 0.5M bicarbonate buffer was added to the spongy capillary matting of the electrode chamber.

Light Measurements

Light measurements were carried out using a solar radiation meter (EMCON, India).

Quantification of proline

Estimation of proline was carried out according to the method of Bates (1973).

Estimation of malondialdehyde content

MDA content was determined as described by Heath and Packer (1968).

RESULTS AND DISCUSSION

The present investigation was designed in such a way as to find out the influence of light on growth and yield performance of *Vanilla*. Table 1 represents the data collected from the 2 different vanillaries for 3 consecutive years. The leaf dry matter percentage was highest in plots receiving 300-600 $\mu\text{E m}^{-2}\text{s}^{-1}$ and 600-800 $\mu\text{E m}^{-2}\text{s}^{-1}$ of sunlight. The plants growing at light intensity above 800 $\mu\text{E m}^{-2}\text{s}^{-1}$ exhibited lower dry matter percentage.

The productivity in terms of fruits formed on a single plant was highest in plots receiving 600-800 $\mu\text{E m}^{-2}\text{s}^{-1}$ of sunlight. The oxygen evolution rate was high in plants receiving 600-800 $\mu\text{E m}^{-2}\text{s}^{-1}$ of sunlight at mid noon (1 pm) while it was low in plants receiving 300-600 $\mu\text{E m}^{-2}\text{s}^{-1}$ of sunlight. It was still less in plants receiving sunlight above 800 $\mu\text{E m}^{-2}\text{s}^{-1}$ (Fig.1). These results clearly showed that effective photosynthesis was taking place in *Vanilla* plants receiving sunlight of 600-800 $\mu\text{E m}^{-2}\text{s}^{-1}$. Photosynthesis was at an appreciable level in plants exposed to 300-600 $\mu\text{E m}^{-2}\text{s}^{-1}$.

$\text{m}^{-2} \text{s}^{-1}$ of sunlight, but only plants exposed to $600\text{-}800 \mu\text{E m}^{-2} \text{s}^{-1}$ sunlight were able to effectively partition the accumulated carbon into fruiting structures. Therefore, as regards productivity, light intensities of $600\text{-}800 \mu\text{E m}^{-2} \text{s}^{-1}$ were the most favoured ones. While sunlight of $300\text{-}600 \mu\text{E m}^{-2} \text{s}^{-1}$ favoured vegetative growth as judged by the fresh weight, dry weight and leaf area (which is the same as that of the plants receiving $600\text{-}800 \mu\text{E m}^{-2} \text{s}^{-1}$ of sunlight), light intensities above $800 \mu\text{E m}^{-2} \text{s}^{-1}$ affected negatively plant productivity (Table 1).

Plants receiving $300\text{-}600 \mu\text{E m}^{-2} \text{s}^{-1}$ sunlight have high levels of total chlorophyll content as compared to $600\text{-}800 \mu\text{E m}^{-2} \text{s}^{-1}$ and above $800 \mu\text{E m}^{-2} \text{s}^{-1}$ (Table 2). More shade is known to result in the synthesis of more chlorophyll as an adaptation strategy to harvest even the weak light reaching to the leaf (Anderson, 1986). The high chlorophyll content, however, did not favour higher rate of oxygen evolution in *Vanilla* plants. This could be due either to the inactiveness of the existing reaction centers or to a reduced number of reaction centers in the leaves. Although there was appreciable oxygen evolution rate in plants exposed to $300\text{-}600 \mu\text{E m}^{-2} \text{s}^{-1}$ sunlight, the carbon accumulated thereon was not partitioned in a productive manner as compared to the plants growing under $600\text{-}800 \mu\text{E m}^{-2} \text{s}^{-1}$ sunlight conditions. It is well known that plants which exhibit effective photosynthesis need not effectively partition their assimilated carbon into fruiting structures (Taiz and Zeiger, 1991), instead, they may add up to the vegetative growth of the plant. This partitioning nature of the assimilated carbon is highly influenced by the genetic feature of the plant as well as the physical conditions of the environment. In *Vanilla* plants, it may be assumed that

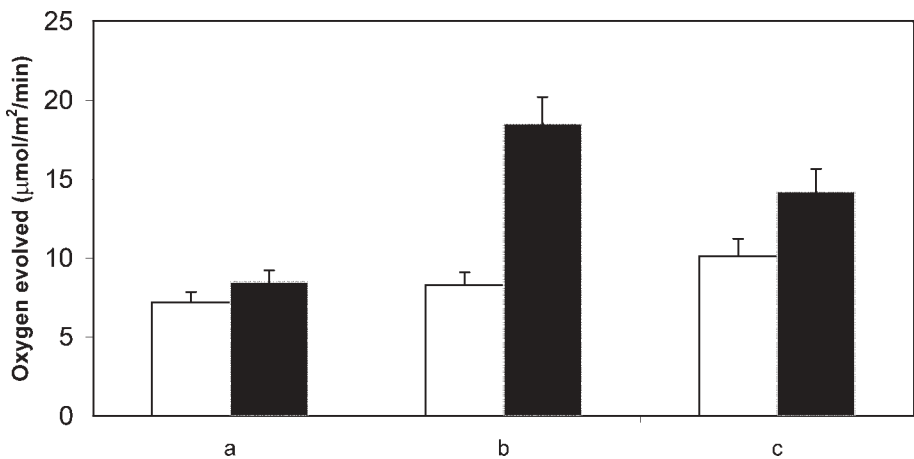

Fig 1. Oxygen evolution in leaves of vanilla plants acclimatized to conditions of varying light intensities. a, above $800 \mu\text{E m}^{-2} \text{s}^{-1}$; b, $600\text{-}700 \mu\text{E m}^{-2} \text{s}^{-1}$ and c, $300\text{-}600 \mu\text{E m}^{-2} \text{s}^{-1}$. (□) and (■) represent measurements done at 8 am and 1 pm, respectively. Vertical bars represent SE of the means from 3 independent experiments with a minimum of 3 replicates each.

Table 1. Growth parameters recorded in *Vanilla* plants growing under conditions of different light intensities. Data are means \pm SE of three independent experiments with three replicates each (i.e. n=9).

Light intensity	300-600 $\mu\text{E m}^{-2} \text{s}^{-1}$	600-800 $\mu\text{E m}^{-2} \text{s}^{-1}$	above 800 $\mu\text{E m}^{-2} \text{s}^{-1}$
Number of inflorescence	4 \pm 0.22	5 \pm 0.27	3 \pm 0.25
Number of flowers/inflorescence	20 \pm 0.97	20 \pm 0.87	15 \pm 1.12
Number of fruits / plants	39 \pm 2.12	80 \pm 3.12	31 \pm 1.12
Leaf area (cm ²)	89 \pm 6.20	89 \pm 7.20	85 \pm 4.70
Fresh wt. of leaf (g)	14.9 \pm 0.81	15 \pm 1.10	14.6 \pm 0.92
Dry wt. of leaf (g)	1.18 \pm 0.07	1.20 \pm 0.05	0.96 \pm 0.07
Percentage of dry matter	7.92 \pm 0.22	8.00 \pm 0.29	6.58 \pm 0.42

Table 2. Pigment composition in leaves of *Vanilla* plants growing under conditions of different light intensities. Data are means \pm SE of three independent experiments with three replicates each (i.e. n=9).

Light intensity $\mu\text{E m}^{-2} \text{s}^{-1}$	Chl. a $\mu\text{g/g FW}$	Chl. b $\mu\text{g/g FW}$	Chl. a/b ratio	Chl. a+b $\mu\text{g/g FW}$	Carotenoids $\mu\text{g/g FW}$	Chl/carotenoid-ratio
300-600	784 \pm 59.6	408 \pm 39.0	1.92	1130 \pm 95.8	120 \pm 10.3	9.42
600-700	638 \pm 52.4	378 \pm 35.4	1.69	1022 \pm 92.3	125 \pm 9.7	8.18
above 800	347 \pm 29.0	188 \pm 17.5	1.85	570 \pm 48.6	144 \pm 11.2	3.96

besides the genetic features, the physical conditions in which the plants grow (light, humidity etc.) may influence the partitioning nature of the assimilated carbon between the vegetative and fruiting structures.

Plants adapted to low light and high light conditions are known to have low (\sim 2 and above) and high (\sim 2.8 and above) chl a/b ratios, respectively (Anderson, 1986). But, surprisingly, no significant differences were observed in the chl a/b ratios in *Vanilla* plants acclimatized to all three light conditions studied. A decreasing chl a/b ratio correlates with increased thylakoid membrane stacking in the chloroplast, and chloroplasts with an increased granal cross sectional area are prone to increased photoinhibition (Anderson and Aro, 1994). Our results for the chl a/b ratios helps us to assume that no significant reorganization of thylakoid membranes has taken place in chloroplasts of the plants adapted to higher light intensities so as to decrease the membrane stacking. Thus, the increased rate of photodestruction in the plants exposed to sunlight above 800 $\mu\text{E m}^{-2} \text{s}^{-1}$ may be directly influenced by the high degree of membrane stacking as judged by the low chl a/b ratio.

The low chlorophyll content in the leaves of plants receiving sunlight above 800 $\mu\text{E m}^{-2} \text{s}^{-1}$ could be a result of increased chlorophyll degradation. Shade adapted plants with large antennae are known to receive high light when exposed to high light

conditions but as a lack of effective channelisation of this energy into photochemical reactions, this energy will culminate in the bleaching of chlorophyll (Anderson, 1986) (Table 2). The extent of photo injury was so severe in the leaves of these *Vanilla* plants that chlorosis took place in the major portion of the leaves indicating an irreversible injury.

Plants with shade adaptive features are highly sensitive to high light. The antennae of the photosynthetic machinery of such plants are unable to channel the light energy to the photochemical reaction centers. This unutilized energy goes stray and finally culminates in the production of free radicals (Powles, 1984). These free radicals can cause damage to the metabolism of the plants resulting in a retarded synthesis rate. This is what was precisely observed in the case of the productivity of *Vanilla* plants growing in sunlight above $800 \mu\text{E m}^{-2} \text{s}^{-1}$ which recorded high levels of lipid peroxidation as analyzed from the MDA content (Fig.2). Plants possess several protection mechanisms against free radicals, such as free radical scavenging enzymes, increased accumulation of carotenoids, proline, etc (Asada et al., 1987; Alia et al., 2002; Arora et al., 2002; Netto et al., 2005). Therefore, it was of interest to see whether any of these mechanisms is operating in *Vanilla* plants to counteract the adverse effects of high light. Our results showed increased proline accumulation with increasing light intensities, the maximum proline being accumulated in the leaves of *Vanilla* plants exposed to light intensities above $800 \mu\text{E m}^{-2} \text{s}^{-1}$ (Fig. 3). Although carotenoids play a major role in light harvesting as accessory pigments (Taiz and Zeiger, 1991), the increase in carotenoid content with increasing light intensities (Table 2) could not justify its role in light harvesting alone. It also acts as a quencher of singlet oxygen species and in avoiding the generation of reactive oxygen species

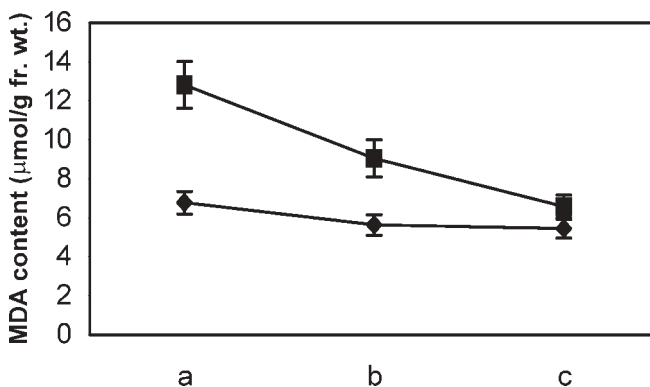

Fig 2. Malondialdehyde (MDA) content in leaves of vanilla plants acclimatized to conditions of varying light intensities. a, above $800 \mu\text{E m}^{-2} \text{s}^{-1}$; b, $600\text{-}700 \mu\text{E m}^{-2} \text{s}^{-1}$ and c, $300\text{-}600 \mu\text{E m}^{-2} \text{s}^{-1}$. (■) and (◆) represent measurements done at 8 am and 1 pm, respectively. Vertical bars represent SE of the means from 3 independent experiments with a minimum of 3 replicates each.

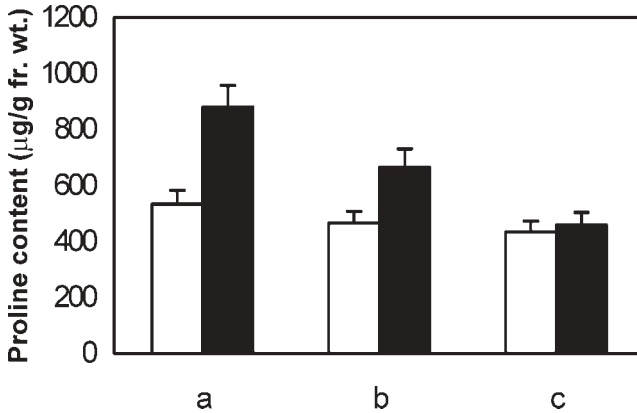

Fig 3. Proline content in leaves of vanilla plants acclimatized to conditions of varying light intensities. a, above 800 $\mu\text{E m}^{-2} \text{s}^{-1}$; b, 600-700 $\mu\text{E m}^{-2} \text{s}^{-1}$ and c, 300-600 $\mu\text{E m}^{-2} \text{s}^{-1}$. (□) and (■) represent measurements done at 8 am and 1 pm, respectively. Vertical bars represent SE of the means from 3 independent experiments with a minimum of 3 replicates each.

by the absorption of excess excitation energy from chlorophyll by direct transfer. Even though both proline and carotenoids were accumulated with increasing light intensities, the percentage of increase was not sufficient to de-energize the free radicals generated. Thus, the after-effects of free radicals generation were exhibited in the productivity of plants exposed to sunlight above 800 $\mu\text{E m}^{-2} \text{s}^{-1}$.

Hendry and Price (1993) have reported that the chlorophyll/carotenoid ratio is a sensitive indicator of photo oxidative damage. Lower values here indicate a higher degree of photo oxidative damage. It was found that *Vanilla* plants exposed to light above 800 $\mu\text{E m}^{-2} \text{s}^{-1}$ had the lowest chlorophyll/carotenoid ratio (3.96), whereas plants exposed to light intensities of 300-600 $\mu\text{E m}^{-2} \text{s}^{-1}$ and 600-800 $\mu\text{E m}^{-2} \text{s}^{-1}$ had higher values for the chlorophyll/carotenoid ratio (9.42 and 8.18, respectively) (Table 2). These results indicate an extensive photo oxidative damage in the leaves of *Vanilla* plants exposed to light above 800 $\mu\text{E m}^{-2} \text{s}^{-1}$.

CONCLUSION

Sunlight varying from 600 to 800 $\mu\text{E m}^{-2} \text{s}^{-1}$ favoured maximum productivity in *Vanilla planifolia* plants whereas light intensities of 300-600 $\mu\text{E m}^{-2} \text{s}^{-1}$ affected to a greater extent plant vegetative growth. Light intensities above 800 $\mu\text{E m}^{-2} \text{s}^{-1}$ led to photo destructive and, in part, photoinhibitory effects on the photosynthetic apparatus. Although the high light conditions are helpful in triggering mechanisms to counteract the photoinhibitory effects, such as accumulation of proline and carotenoids, our results showed that these mechanisms were not fully capable of protecting the

plants against photoinhibitory effects. Therefore, sunlight above $800 \mu\text{E m}^{-2} \text{s}^{-1}$ can bring about a drastic reduction in the productivity of *Vanilla*.

Acknowledgements: The author is grateful to the Department of Science and Technology, Govt. of India, for the Fast Track Young Scientist Project (SR/FTP/LS-21/2001) awarded to him. The author is grateful to P.J. Johnson for critically evaluating the language of this manuscript.

References

- Alia, J. Matysik, B. Bhalu, P. Mohanty, 2002. Molecular mechanisms of quenching of reactive oxygen species by proline under stress in plants. *Current Sci.*, 82, 525-530.
- Anderson, J.M., 1986. Photoregulation of the composition, function, and structure of thylakoid membranes. *Annu. Rev. Plant Physiol.*, 37, 93-136.
- Anderson, J.M, E. Aro, 1994. Grana stacking and protection of photosystem II in thylakoid membranes of higher plant leaves under sustained high irradiance: An hypothesis. *Photosyn. Res.*, 41, 315-326.
- Arnon, D.I., 1949. Copper enzymes in isolated chloroplast polyphenoloxidase in *Beta vulgaris*. *Plant Physiol.*, 24, 1-15.
- Arora, A., R.K. Sairam, G.C. Srivastava, 2002. Oxidative stress and antioxidative system in plants. *Current Sci.*, 82, 1227-1236.
- Asada, K., M. Takahashi, 1987. In: *Photoinhibition Topics in Photosynthesis*, Ed. D.J. Kyle, C.B. Osmond, C.J. Arnten, Elsevier, Amsterdam, 9, 227-287.
- Bates, L.S., R. P. Waldern, I. Teare, 1973. Rapid determination of free proline for water-stress studies. *Plant Soil*, 39, 205-207.
- Evans, L. T., 1972. *The qualitative analysis of plant growth*. Blackwell Scientific Publisher, Oxford, London.
- Heath, R.L, L. Packer, 1968. Photoperoxidation in isolated chloroplasts. I. stoichiometry of fatty acid peroxidation. *Arch. Biochem. Biophys.*, 125, 189-198.
- Hendry, G.A.F, A.H. Price, 1993. Stress indicators: chlorophylls and carotenoids. In: *Methods in comparative plant ecology*, Ed. G.A.F. Hendry, J.P. Grime, Chapman & Hall, London, 148-152.
- McKinney, G., 1941. Absorption of light by chlorophyll solutions. *J. Biol. Chem.*, 140(2), 315-322.
- Natu, P.S., M.C. Ghildiyal, 2005. Potential targets for improving photosynthesis and crop yield. *Current Sci.*, 88, 1918-1928.
- Netto, L.A., K.M. Jayaram, P. Haridas, J. T. Puthur, 2005. Characterization of photosynthetic events and associated changes in tea (*Camellia sinensis L.*) under conditions of low temperature and high light. *J Plant Biol.* (in press).
- Philip, V.J., P. Tessey, 1990. Clonal propagation of *Vanilla planifolia*. Proc. of National seminar on Biotechnological approaches for upgradation of agricultural and horticultural crops. TNAU, Coimbatore, India.

- Powles, S.B., 1984. Photoinhibition of photosynthesis induced by visible light. *Annu. Rev. Plant Physiol.*, 35, 15-44.
- Purseglove, J.W., E.G. Brown, C. L. Green, S.R.J. Robbins, 1981. *Vanilla*. In: Spices. Vol. II. Longman Scientific & Technical publisher, England, 644-735.
- Puthur, J.T., P. Sharmila, K.V.S.K. Prasad, P.P. Saradhi, 1996. Proline over production: A means to Improve Stress tolerance in crop plants. *The Botanica*. 46, 163-169.
- Saini, A.D., R. Nanda, 1986. Relationship between incident radiation, leaf area index and dry matter yield in wheat. *Indian J. Agri. Sci.*, 56, 638-645.
- Shanmugavelu, K.G., N. Kumar, K. V. Peter, 2002. In: Production technology of spices and plantation crops, Ed. U. Purohit, Agrobios, India, 63-70.
- Shivashankara, K.S., J. Mithila, S. Maiti, 2000. Effect of different light intensities on growth and yield of Betevine (*Piper betle* L.) *J. Plantation Crops*, 28,196-200.
- Singh, S., 1994. Physiological response of different crop species to light stress. *Indian J. Plant Physiol.*, 37, 147-151.
- Sudharshan, M.R., K. John, 2003. *Vanilla status paper*. Published by spices board, Ministry of commerce, Govt. of India, Cochin, 2-24.
- Taiz, L., E. Zeiger, 1991. *Plant Physiology*. The Benjamin/Cummings publishing company, Inc. 390 Bridge Parkway, Redwood City, California 94065.
- Vyas, S.P., 2004. Influence of light intensity on growth, yield and lawsone content of henna (*Lawsonia innermis* L.). *Indian J. Plant Physiol.*, 9, 275-277.
- Vyas, S.P., S. Kathju, B.K. Garg, A.N. Lahiri, 1996. Response of clusterbean genotypes to shade. *Indian J. Plant Physiol.*, 1, 234-238.
- Vyas, S.P., S. Nein, 1999. Effect of shade on growth of *Cassia aungustifolia*. *The Indian Forester*, 125, 407-410.

MORPHOGENETIC EFFECTS OF MERCURY IN *LAGENARIA SICERARIA* (MOL) STANDL AND THEIR PARTIAL REVERSAL BY EXOGENOUS AUXIN

Aisha Saleem Khan ^{*1} and Najma Yaqub Chaudhry²

¹Punjab University, Botany Department, Pakistan, ²Punjab University, Botany Department, Lahore

Received 27 December 2005

Summary. The effects of mercuric chloride (HgCl_2), indole-3-acetic acid (IAA) and their combination on the development of different cell types in the stem of *Lagenaria siceraria* (Mol) Standl. were studied. Mercury treatment resulted in a reduced stem diameter when compared to untreated control plants. This is attributed to a decrease in the diameter of fibre cells, sieve tube members, large xylem vessels and phloem cells as well as to the interference with cambium development. IAA treatment caused enhanced growth of cambial region, sieve tube members and xylem vessels both in transverse and longitudinal planes. Application of HgCl_2 in combination with IAA caused less reduction in growth parameters, thus suggesting that the inhibitory effect of mercury can be restored to some extent due to the application of IAA.

Keywords: Auxin; *Cucurbitaceae*; mercury; secondary growth; sieve tube members; xylem vessels.

Abbreviations: IVC - inner vascular cylinder; OVC - outer vascular cylinder.

INTRODUCTION

Normally in the environment plants are exposed to a range of abiotic stresses like osmotic, salinity, temperature and heavy metals toxicity, which affect their growth and other physiological processes (Levitt, 1980). Heavy metals cause irreversible damage to a number of vital metabolic constituents in plants (Tomar et al., 2000).

Disorders in biochemical process which affect the growth and vitality of plants are often observed. Furthermore, cell wall metabolism, cell elongation as well as cellular volume are reduced (Olivares et al., 2002).

Mercury which occurs naturally in the environment is highly toxic (Thangavel et al., 1999) and exists in several forms, such as metallic mercury, inorganic and organic mercury. Diverse biochemical and structural changes in tissues of green plants in response to mercury have been reported (Neculita et al., 2005). Plants which adapt to growth in the presence of HgCl_2 exhibit extensive morphological abnormalities. Furthermore, mercury decreases the water translocation to leaves by reducing the radius of vessels and by partial blockage of cellular debris and gums (Lamoreaux and Chaney, 1977).

Auxins, gibberellins, cytokinins, ethylene and abscisic acid are well known plant hormones which play an integral role in controlling growth, development, metabolism and morphogenesis of higher plants (Taiz and Zeiger, 1991; Stoyanova et al., 1996). IAA (indole-3-acetic acid) is the major auxin involved in many physiological processes in plants. It stimulates cell elongation, differentiation of xylem and phloem and controls cambial growth (Wang et al., 1997). IAA is involved in the initiation of lateral roots and usually it accumulates in high amounts in the pericycle (Blakesley et al., 1991).

MATERIALS AND METHODS

Seeds of *L. siceraria* (Mol.) Standl. were sown in pots (5 kg soil capacity). The plants were watered at regular intervals and were maintained under natural conditions of light, temperature and humidity. Different concentrations of HgCl_2 and IAA were applied either individually or in combinations as follows: 50 ppm HgCl_2 , 100 ppm HgCl_2 , 400 ppm IAA, 50 ppm HgCl_2 + 400 ppm IAA and 100 ppm HgCl_2 + 400 ppm IAA. There were five replicates for each treatment. IAA was applied on the plant apical meristem 24h after cotyledonary leaves were opened. HgCl_2 treatment was applied through the soil three times in a week. Plants were grown for 45 days.

To study the internal morphology (Sanderson, 1994) plant material was firstly dehydrated in an ascending series of water, ethyl alcohol and tertiary butyl alcohol mixture, infiltrated and embedded in paraffin wax. The embedded material was processed using rotary microtome (Reichert- Jung, Nippon Optical Work, Japan). It was fixed on glass slides by using adhesive material prepared from equal amounts of egg albumin and glycerine. It was then passed through a descending series of alcohol kept in safranin followed by an ascending series of alcohol. Slides were dipped in fast green, passed through an ascending series of xylene and mounted in Canada balsam. All observations were subjected to statistical analysis (Steel and Torrie, 1981).

RESULTS

Parameters studied in transection

The width of epidermal cells was $15.1\mu\text{m}$ in the control samples (Table I). This parameter differed significantly in the variants treated with IAA and HgCl_2 (Table I). HgCl_2 applied at a concentration of 100ppm caused 28.8% inhibition of the cortical region and 20.19% reduction of the sclerenchyma region compared to controls (Fig. 2). In contrast, treatment with 400 ppm IAA resulted in an expansion (by 8.9%) of the sclerenchyma region. Combined treatments influenced insignificantly the studied parameters regarding the sclerenchyma (Table I).

Vascular region

There are two types of vascular cylinders in transection of the internode of *L. siceraria* (Mol) Standl which are bicollateral. The rings of the large inner vascular cylinder (IVC) and the outer small vascular cylinder (OVC) are situated between the ridges of assimilation parenchyma (Fig.1).

Application of 50 ppm and 100 ppm HgCl_2 inhibited the size of the external and internal phloem regions in the external phloem of IVC (Table I, Fig. 1-3). Application of 400 ppm IAA enhanced both upper and lower phloem regions (Table I, II). Increased growth of cambial region was registered after 400 ppm IAA treatment. As a consequence, 9 upper and 4 lower cambial layers were observed (Fig. 4).

Vessels having a diameter above $50\mu\text{m}$ were considered to be large-sized xylem vessels. Our results showed 18.4% and 24.9% inhibition of IVC in plants treated

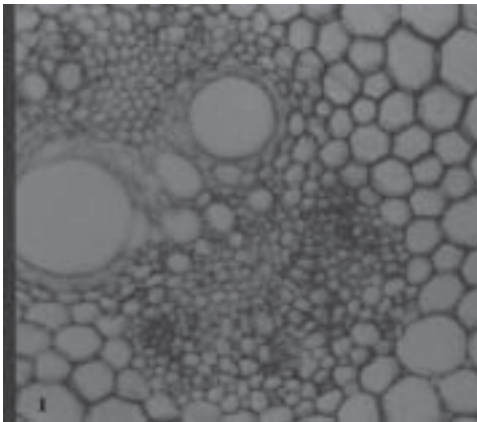

Figure 1. Transection of *Lagenaria siceraria* (Mol) Standl. internode

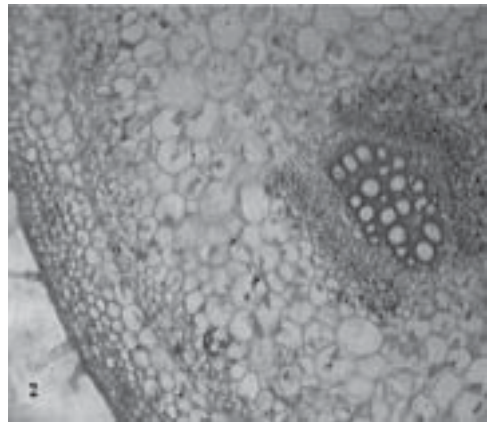

Figure 2. Internode treated with 50 ppm HgCl_2

Table I. Effects of HgCl₂ and IAA on the internode of inner vascular cylinder (IVC) of *Lagenaria siceraria* (Mol) Standl. in transection (results are means of five replicates).

Treatments (ppm)	Width of epidermal cells(μm)	Diameter of cortical region (μm)	Diameter of sclerenchyma region (μm)	Diameter of external phloem region (μm)	Diameter of internal phloem region (μm)	Number of upper-cambial layers	Number of lower-cambial layers	Width of metaxylem vessel (μm)	Width of protoxylem elements (μm)
Control	15.1± 0.04	114.2± 0.17	84.2 ± 0.26	87.2± 0.36	62.6 ± 0.74	6± 0.02	3± 0.51	68.2 ± 0.68	53.8 ± 0.82
50 (ppm) HgCl ₂	13.4 ± 0.28	92.3 ± 0.57	73.4 ± 0.79	75.2 ± 0.48	54.9 ± 0.92	4± 0.71	3 ± 0.46	55.6 ± 0.19	45.1 ± 0.51
100 (ppm) HgCl ₂	12.2 ± 1.38	81.2 ± 0.04	67.2 ± 0.93	64.3 ± 0.05	47.2 ± 0.58	4 ± 0.55	3 ± 0.89	51.2 ± 0.15	37.4 ± 0.02
400(ppm) HgCl ₂	14.6 ± 0.69	132.4 ± 0.51	91.7± 0.05	98.7 ± 0.69	77.5 ± 0.35	9.2 ± 0.01	4 ± 0.36	78.9 ± 0.73	63.2 ± 0.03
IAA 50(ppm)	14.9± 0.39	105.3 ± 0.35	78.9 ± 0.48	83.5 ± 0.23	59.5± 0.49	5.6 ± 0.36	3 ± 0.11	61.6 ± 0.17	50.7 ± 0.87
HgCl ₂ + 400(ppm) IAA	14.0 ± 0.01	93.2 ± 0.48	74.3 ± 0.07	71.2± 0.17	53.2 ± 0.03	5.8 ± 0.24	3 ± 0.92	58.2 ± 0.83	44.6 ± 0.99
100 (ppm) HgCl ₂ + 400 (ppm) IAA									
LSD at 0.05	0.27	3.76	2.46	2.98	5.37	0.72	0.27	2.16	4.58

with 50 ppm HgCl_2 and 100 ppm HgCl_2 , respectively (Fig. 2, 3). However, application of IAA led to an increase (by 15.6%) of the xylem vessels (Fig. 4). Mixed doses caused an inhibition of the studied parameters compared to controls (Table I, II). Treatment with 50 ppm HgCl_2 and 100 ppm HgCl_2 caused an inhibition of protoxylem vessels in IVC and OVC (Fig. 2, 3).

Parameters studied in a longitudinal plane

Annular, spiral and helical thickenings of protoxylem elements were observed in *L. siceraria* (Mol) Standl (Fig 5). IAA promoted the diameter of spiral and helical pro-

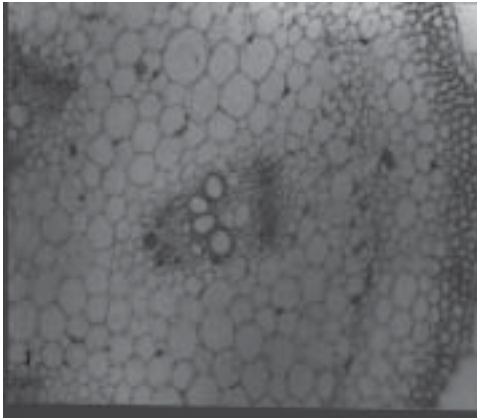

Figure 3. Effect of 100 ppm HgCl_2 on cambial growth and diameter of xylem vessels

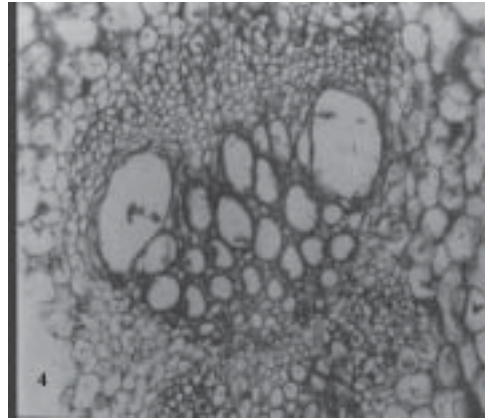

Figure 4. Enhanced cell division with 400 ppm IAA

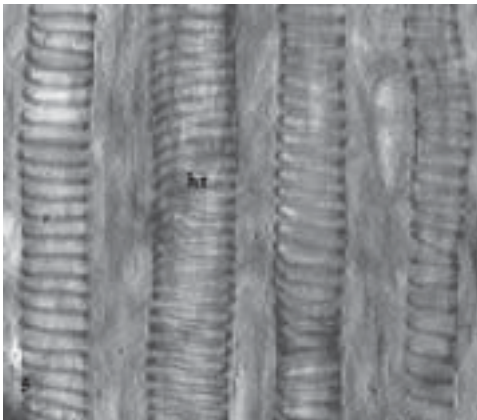

Figure 5. Helical thickenings (ht) of protoxylem vessels in control

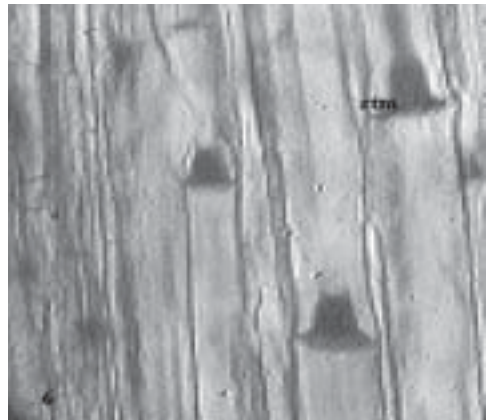

Figure 6. Sieve tube members (stm) in control

Table II. Effects of HgCl₂ and IAA on the internode of outer vascular cylinder (OVC) of *Lagenaria siceraria* (Mol) Standl. in transection (results are means of five replicates)

Treatments (ppm)	Width of metaxylem vessels (μm)	Width of protoxylem elements (μm)	Diameter of external phloem region (μm)	Diameter of internal phloem region (μm)	Number of upper cambial layers	Number of lower cambial layers	Diameter of cellular pith region (μm)	Diameter of fistular pith region (μm)
Control	44.6 ± 0.14	31.2 ± 0.65	76.7 ± 0.03	38.2 ± 0.05	5 ± 0.17	4 ± 0.39	98.3 ± 0.29	243.2 ± 0.18
50 (ppm) HgCl ₂	38.8 ± 0.12	25.3 ± 0.29	71.5 ± 0.58	33.4 ± 0.92	3 ± 0.04	2 ± 0.18	84.6 ± 0.73	254.9 ± 0.57
100 (ppm) HgCl ₂	32.4 ± 0.17	21.1 ± 0.85	63.1 ± 0.97	27.4 ± 0.39	3 ± 0.18	2 ± 0.06	75.7 ± 0.92	261.5 ± 0.09
400 (ppm) IAA	57.3 ± 0.76	40.4 ± 0.64	82.5 ± 0.08	46.5 ± 0.19	9 ± 0.13	3 ± 0.12	103.5 ± 0.87	225.1 ± 0.06
50 (ppm) HgCl ₂ + 400 (ppm) IAA	41.9 ± 0.45	29.5 ± 0.06	74.2 ± 0.16	37.2 ± 0.97	5 ± 0.04	3 ± 0.15	87.9 ± 0.72	236.5 ± 0.34
100 (ppm) HgCl ₂ + 400 (ppm) IAA	43.8 ± 0.56	27.4 ± 0.22	67.8 ± 0.67	32.1 ± 0.11	4 ± 0.36	2 ± 0.06	82.4 ± 0.27	254.8 ± 0.28
LSD at 0.05	6.24	2.18	5.17	2.96	1.82	1.26	6.72	5.28

Table III. Effects of HgCl₂ and IAA on *Lagenaria siceraria* (Mol) Standl. internode in longitudinal view (results are means of five replicates)

Treatment (ppm)	Width of helical thickening of protoxylem vessel (μm)	Width of spiral thickening of protoxylem vessel (μm)	Width of sieve tube members (μm)	Width of pitted metaxylem vessel (μm)	Width of fusiform cambial cells (μm)
Control	54.2 ± 0.02	43.5 ± 0.31	36.4 ± 0.19	221.4 ± 0.37	9.5 ± 0.45
50 HgCl ₂	45.1 ± 0.37	37.2 ± 0.04	28.7 ± 0.07	211.3 ± 0.43	7.21 ± 0.38
100 HgCl ₂	41.2 ± 0.93	33.8 ± 0.67	23.6 ± 0.15	204.4 ± 0.82	7.11 ± 0.95
400 IAA	62.4 ± 0.24	47.1 ± 0.46	42.5 ± 0.24	237.7 ± 0.74	14.7 ± 0.26
50 HgCl ₂ + 400 IAA	50.2 ± 0.36	41.6 ± 0.09	32.2 ± 0.72	217.5 ± 0.06	9.3 ± 0.45
100 HgCl ₂ + 400 IAA	46.3 ± 0.93	39.5 ± 0.28	28.6 ± 0.36	212.8 ± 0.82	8.4 ± 0.29
LSD at 0.05	3.28	2.47	2.15	5.06	1.21

toxylem elements (Table III). Treatment with IAA applied at a concentration of 400 ppm stimulated growth in diameter of metaxylem vessels and sieve tube members (Fig 6, 7, 9 and 10). Application of different HgCl_2 concentrations inhibited significantly the helical thickenings, fusiform initials and width of pitted metaxylem vessels (Fig 8, Table III).

DISCUSSION

In the present study, epidermal cells of the internode showed negligible response to all treatments. Similar results describing the unresponsiveness of epidermal cells

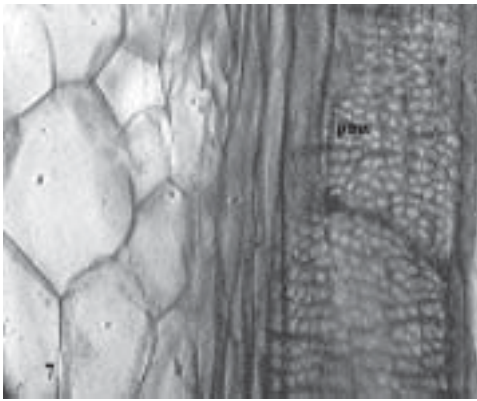

Figure 7. Pitted metaxylem vessels (pmv) in control

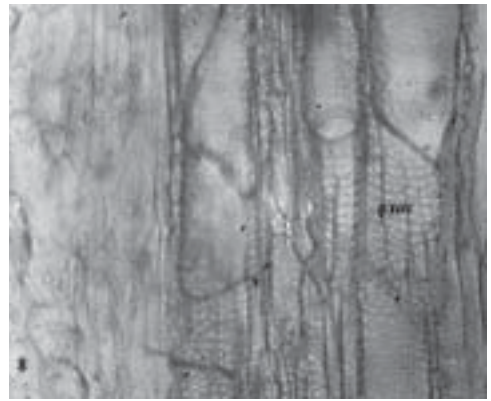

Figure 8. Inhibitory effect of 100 ppm HgCl_2 on pitted metaxylem vessel (pmv)

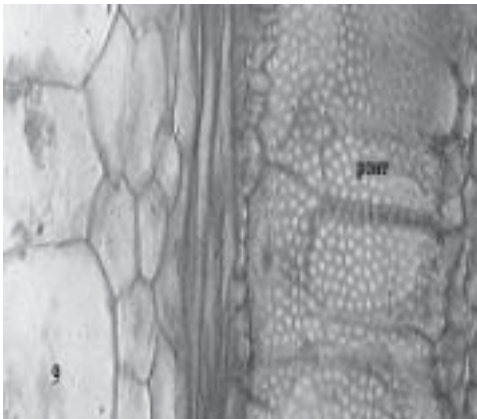

Figure 9. 400 ppm IAA promoted pitted metaxylem vessel (pmv)

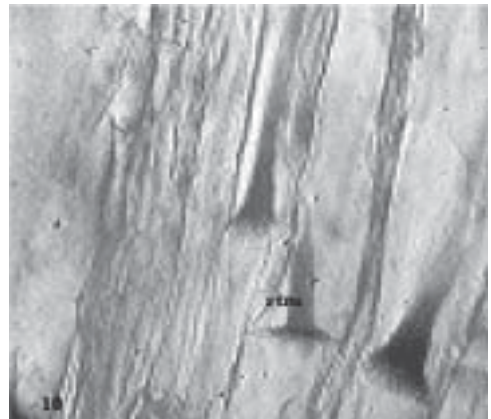

Figure 10. 400 ppm IAA promoted growth of fascinating bells (sieve tube members)

after various applications have been previously reported (Wardlaw, 1957). Application of HgCl_2 hampered the growth of fibre cells and cortical region. The higher dose of 100 ppm was found to inhibit stronger the studied parameters when compared with 50 ppm HgCl_2 . These results support previously reported observations that higher metal concentrations which accumulate in different plant parts induce higher toxic effects (Gothberg et al., 2004).

Xylem vessels (including metaxylem and protoxylem elements) showed reduced growth when treated with HgCl_2 in both transverse and longitudinal planes (Table I, II and III). This can be due to a reduction of vessels radius caused by mercury application, thus leading to partial blockage with cellular debris and gums (Lamoreaux and Chaney, 1977). The growth of sieve tube members and cambial region was inhibited after 100 ppm HgCl_2 treatment (Barcelo et al., 1988). Plants adapted to grow in the presence of HgCl_2 exhibit extensive morphological abnormalities (Vaituzis et al., 1975). Our results support the above findings as reduced cell division was reported in vascular region in plants submitted to HgCl_2 treatment (Table I and II).

IAA applied at a concentration of 400 ppm caused expansion in cortical, sclerenchyma and cambial regions. Both xylem and phloem development was enhanced by IAA application (Reed, 2001). Auxins are key signals in secondary xylem formation (Wang et al., 1997). Similar results were observed in the present study as large xylem vessels and phloem region showed enhanced growth after IAA treatment and this was accompanied by increased cambial growth (Table I and II). They not only stimulated cambial cells mitosis, but also caused new daughter cells to differentiate to xylem cells. As a result of exogenous IAA treatment wider vessels were produced (Wareing and Roberts, 1956).

IAA affects plant growth in many ways including cell growth expansion in the vascular cambium (Awan et al., 1999). Similar was the observation made in *L. siceraria* treated with IAA. Plant cells elongate irreversibly only when load-bearing bonds in the walls are cleaved. Usually auxins cause the elongation of stem and coleoptile cells by promoting wall loosening via cleavage of these bonds (Rayle and Cleland, 1992). Increased cell expansion due to IAA application observed in the present study can be attributed to cell wall loosening and increased cell wall plasticity.

Simultaneous application of HgCl_2 with IAA showed that growth reduction imparted by mercury could be counteracted to some extent by IAA. Application of 50 ppm HgCl_2 + 400 ppm IAA reduced growth of fibre cells, cortical and cambial regions. However, this effect was weaker than in plants treated with 50 ppm HgCl_2 alone (Table I). This was due to the presence of IAA and particularly to its well-known effects on vascular differentiation (Alam et al., 2002). Similarly in plants treated with the mixture of 100 ppm HgCl_2 and 400 ppm IAA, the growth of the cambial region was inhibited to a higher extent when compared to 50 ppm HgCl_2 +

400 ppm IAA-treated plants. This was due to the increased HgCl_2 concentration (Gothberg et al., 2004). The present study suggests that IAA treatment can partially restore cambial growth in plants under mercury stress.

References

- Alam, S.M., A. Shereen, M.A. Khan, 2002. Growth and response of wheat cultivars to NAA and Ethrel. *Pakistan J. Bot.*, 34,135-137.
- Awan, I., M.S. Baloch, N.S. Sadozai, M.Z. Sulemani, 1999. Stimulatory effect of GA and IAA on ripening, kernel development and quality of rice. *Pak. J. Biol. Sci.*, 2, 410-412.
- Blakesley, D., G.D., Weston, J.F, Hall, 1991. The role of endogenous auxin in root initiation. Part I: Evidence from studies on auxin application, and analysis of endogenous levels. *Plant Growth Regul.*, 10, 341-353.
- Gothberg, A., M. Greger, K. Holm, B.E. Bengtsson, 2004. Influence of nutrient level on uptake and effects of mercury, cadmium and lead in water spinach. *J. Environ. Quality*, 33: 1247- 1255.
- Lamoreaux, R.J, W.R. Chaney, 1977. Growth and water movement in silver maple seedlings affected by cadmium, *J. Environ. Quality*, 6, 201–205.
- Levitt, J., 1980. *Plant Responses to Environmental Stress*. Vol. I. Academic Press, London.
- Neculita, C.M, J.Z. Gerald, D. Louis, 2005. Mercury speciation in highly contaminated soils from Chlor- Alkali plants using chemical extractions. *J. Environ.*, 34, 255-262.
- Olivares, E, E. Pena, G. Aguiar, 2002. Metals and oxalate in *Tithonia diversifolia* (Asteraceae): concentrations in plants growing in contrasting soils, and Al induction of oxalate exudation by roots. *J. Plant Physiol.*,159, 743-749.
- Rayle, D.L., R.E. Cleland, 2000. The acid growth theory of auxin-induced cell elongation is alive and well. *Plant Physiol.*, 99, 1271-1274.
- Reed, J.W., 2001. Roles and activities of Aux/ IAA proteins in *Arabidopsis*. *Trends in Plant Sci.*, 6, 420-425.
- Sanderson, J.B., 1994. *Biological and Microtechniques*. BIOS Scientific Publishers Limited, St Thomas House, Becket Street, Oxford, OXI 1SJ, UK.
- Steel, R.G., J.H., Torrie, 1981. *Principles and Procedures of Statistics*. New York: McGraw Hill.
- Stoynova, E., L. Iliev, G. Georgiev, 1996. Structural and functional alterations in radish plants induced by the phenylurea cytokinin 4-PU-30. *Biologia Plantarum*, 38(2), 237-244.
- Taiz, L., E. Zeiger, 1991. Auxin growth and tropism. In: *Plant Physiology*. The Benjamin/Cummings Publishing Co.Inc. California. p 398-42.
- Thangavel, P., A.S. Sulthana, V. Subburam, 1999. Interactive effects of selenium and mercury on the restoration potential of leaves of medicinal plants *Portulaca oleracea* L. *Sci Total Environ.*, 243-244, 1-8.
- Tomar M., I. Kaur, N. Bhatnagar, A.K. Bhatnagar, 2000. Effect of enhanced lead in soil on growth and development of *Vigna radiata* (L). *Indian J. Plant Physiol.*, 5, 13–18.

- Vaituzis, Z., J.D. Nelson, L.W. Wan, R. Colwell, 1975. Effects of mercuric chloride and morphology of selected strains of mercury resistant bacteria. *Applied Microbiol.*, 29, 275-286.
- Wang, Q., C.H.A. Little, P.C., Oden, 1997. Control of longitudinal and cambial growth by gibberellic acid and indole-3-acetic acid in shoots of *Pinus sylvestris*. *Physiologia Plantarum*, 95, 187-194.
- Wardlaw, W. 1952. *Phylogeny and Morphogenesis*. MacMillan and Co. Ltd., St. Martin's Street, London.
- Wareing, P.F, D.L., Roberts, 1956. Photoperiodic control of cambial activity in *Robinia pseudoacacia* L. *New Phytol.*, 55, 289-295.

FUNGAL ELICITOR-MEDIATED CHANGES IN POLYAMINE CONTENT, PHENYLALANINE-AMMONIA LYASE AND PEROXIDASE ACTIVITIES IN BEAN CELL CULTURE

F. Broetto ^{1*}, J.A. Marchese ³, M. Leonardo ², M. Regina ²

¹Institute of Biosciences, São Paulo State University, Botucatu 18618-000, Brazil;

²Agronomic Sciences College, São Paulo State University, Botucatu 18603-970, Brazil;

³Agronomy College, Paraná Federal University of Technology, Pato Branco, 85503-390, Brazil.

Received 07 March 2005

Summary. Plant cells are able to shift their metabolism in response to aggressive environmental factors such as salinity, water stress, anoxia, flooding or biotic elicitors. In this work, cell suspensions of four bean (*Phaseolus vulgaris* L.) genotypes were stabilized and treated with elicitors isolated from fungal (*Fusarium oxysporum* f. sp. phaseoli) cell walls. The elicitation of the cells was effective in the induction of the activity of L-phenylalanine-ammonia lyase (PAL), a key enzyme related to defense reactions, as well as the peroxidase, an enzyme related to the antioxidative response system. The same effect was also verified in relation to the polyamine metabolism, mainly for the accumulation of the diamine putrescine. The obtained results give important information regarding the plant-pathogen interactions, mainly as subsidy for bean improvement programs seeking the adaptation to adverse environmental factors.

Key words: peroxidases, phenylalanine-ammonia lyase, polyamines, fungal elicitor, tissue culture

Abbreviations: E.C. - enzyme classification, MS - Murashige & Skoog medium, PA - Polyamines, PAL - phenylalanine ammonia-lyase, POD - peroxidases, TLC - thin layer chromatography, Phe - phenylalanine

* Corresponding author, e-mail: broetto@ibb.unesp.br

INTRODUCTION

Bean culture is susceptible to a large number of fungal diseases, among which is the wilt caused by *Fusarium oxysporum* (Nascimento et al., 1995). In Brazil, the disease is found in the South, Southeast and Northeast of the country where it is considered as a limiting factor to the production (Ribeiro and Ferraz, 1984).

In general, plants have potential to mobilize biochemical response mechanisms against pathogenic attack including lignification (Köhle et al., 1985), suberization (Espelie et al., 1986), synthesis of phytoalexins (Kuc and Rush, 1985), induction of hydrolytic enzymes (Bollen, 1985; Broetto, 1995) and activation of the antioxidative response system (Broetto et al. 2002). The regulation of enzymes involved in the biosynthesis of metabolites produced in response to environmental stress has been studied in cell cultures of different plant species (Messner et al., 1991), aiming to accelerate *in vivo* studies. Schell & Parker (1990) suggested that the activation to the phenylpropanoid metabolism can be easily detected by the variation in the activity of its key enzyme, phenylalanine-ammonia lyase (PAL, E.C.4.3.1.5.). In another study, Lawton et al. (1983) treated a bean cell culture using a cell wall isolate of the fungus *Colletotrichum lindemuthianum*. As a response they observed a strong induction of PAL activity which was due to increased *de novo* synthesis of PAL-mRNA.

Bell et al. (1984) differentiated compatible and non-compatible bean cultivars according to their response to the pathogenic infection. The non-compatible cultivars (considered resistant) when infected accumulated high amounts of the phytoalexine phaseolin, accompanied by the increase of PAL activity and PAL-mRNA. A study of the induction of the activity of PAL and 4-coumarate-CoA-ligase after treatment of carrot cells with elicitors extracted from the fungus *Pythium aphanidermatum* showed similar correlations (Gleitz, 1989).

Campbell and Ellis (1992) treated cells of *Pinus banksiana* using ectomicorrhizal fungi as elicitors. They found that the activity of PAL was increased almost 10 times after 24-h treatment. The lignification of the elicited tissue was accompanied also by an increase of the activity of enzymes associated with the synthesis of lignin, such as caffeic acid *O*-methyl transferase, 4-coumarate-CoA-ligase and peroxidases. The peroxidases (EC 1.11.1.7) compose a group of enzymes stimulated in typical defense responses using H₂O₂ in several biological oxidation processes and they are involved in the pathogen enzyme inactivation by phenolic oxidation (Siegel, 1993; Broetto, 1995). The lignification of the infected plant tissues can be considered as a resistance mechanism (Vance et al. 1980). The final polymerization of lignin is due to the oxidation of the phenolic groups mediated by the enzyme peroxidase (Pascholati and Leite, 1995).

Another important subject of the study of plant-pathogen relationships is the amine metabolism, particularly the aliphatic di- and polyamines. Although less explored

this line of studies can contribute to the understanding of the adaptation strategies of plant cells in response to environmental stresses (Walters, 2000).

In plant tissues, di- and polyamines are detected in micromolar order and to above millimolar, depending to a great extent to the environmental conditions, especially stress (Flores and Filner, 1985). Some alterations in the polyamine metabolism in plants were reported by Slocum et al. (1984), as a response to fungal elicitation. Samborski and Rohringer (1970) mentioned that resistant wheat cultivars were elicited using several species of pathogens, accumulating putrescine conjugated to phenolic compounds, such as hydroxycinnamic acid. This compound (2-hydroxyputrescine) possesses anti-microbe activity acting as phytoalexin. In leaves of barley infected by the fungus that causes the brown rust, Greenland and Lewis (1984) observed that chlorophyll was retained in sites of infection (called *green islands*), and in these tissues, the level of spermidine increased 6 - 7 times. Other amines conjugated with phenols, such as dicoumaroylagmatine, were found by Smith and Best (1978) after infection of barley seedlings by powdery mildew (*Erysiphe graminis*). The agmatine, coumaroylagmatine and dicoumaroylagmatine concentrations were detected in growth phases between 3 and 13 days after the inoculation. The authors observed that the infection induced an increase in the levels of hordantine (6 times) and agmatine (2 times) 13 days from inoculation of the seedlings. Walters & Wylie (1986) also observed that application of elicitors of fungus that causes powdery mildew in barley induced an increase in levels of polyamines in the young leaves as well as in the activity of the enzymes related to polyamine metabolism.

The aim of the present study was to examine some metabolic shift in cells of bean (*Phaseolus vulgaris* L.) treated with fungal elicitors with an emphasis on polyamine metabolism and enzymes related to resistance mechanisms to stress biological factors.

MATERIALS AND METHODS

Plant material and growth conditions

Seeds of four bean genotypes: IAC-carioca SH 80, IAPAR-14, JALO-EEP 558 and BAT-93 were used throughout the experiments. The callus cultures were established starting with the inoculation of embryo axes in a MS semi-solid medium (Murashige & Skoog, 1962) supplemented with organic components and plant regulators as described by Broetto (1995). After 28 days the bean calluses were disaggregated in stainless steel sieves (0.5 - 1.0 mm) and simultaneously washed with liquid MS medium. The cells were collected in a Nylon net (0.45 μm), suspended in liquid MS medium and transferred into flasks containing 50 mL of MS medium (4.0 mg of cells mL^{-1} of medium). The cell suspensions were maintained under agitation (110 rpm) in a culture room at 26 °C and light intensity of 2000 lux.

Fungal culture

An isolated culture of the *Fusarium oxysporum* f. sp. *phaseoli* was kindly provided by Dr. A.C. Maringoni, from the fungal collection of the Agronomy College at São Paulo State University, Botucatu, SP, Brazil. The fungi were initially cultivated on Petri dishes in a PDA medium (PDA; potato, dextrose, agar) maintained at 28 °C, until optimum mycelium growth (7 to 10 days).

The isolation of *Fusarium oxysporum* cell walls was done according to the protocol of Ayers et al. (1976) adapted by Broetto (1995). The determination of total soluble sugars (Dubois et al., 1956) was required as a dilution parameter (glucose equivalents).

The solution was centrifuged to isolate the particles in suspension and applied aseptically to the cultures of bean cells with a Millipore 0.2 µm membrane. The beans cell cultures were collected 48 h after elicitation and used further for biochemical determinations.

Suspensions of bean cells were established in triplicates (50 mL of medium, containing 4 mg of cells mL⁻¹) and received the elicitor solution as of the following treatments: 50, 100 and 200 (g mL⁻¹ glucose equivalents). The control treatment received sterilized deionized water (1.0 mL) substituting the elicitor treatment.

The treatments denominated glucose equivalents represent the concentration of total soluble sugars after dilution with distilled water (to 1.0 mL). In this analysis, the hydrolyzed solutions presented concentrations of 200 µg glucose mL⁻¹. Samples of fresh cells (1 g) were macerated into 5 mL of potassium phosphate buffer, pH 6.7, 0.2 mol L⁻¹. After centrifugation at 12100 x g for 10 min at 4 °C, the supernatant was collected, distributed into glass vials and frozen at -20 °C.

Biochemical determinations

The concentration of soluble proteins present in the crude extract was determined in triplicate using the assay described by Bradford (1976) with bovine serum albumin as a standard.

Determination of peroxidase activity (POD; E.C 1.11.1.7) was done by the method of Allain et al. (1974). The enzyme activity was calculated using the molar extinction coefficient of 2.47 mM⁻¹ cm⁻¹. The specific activity was expressed as µM H₂O₂ min⁻¹ mg⁻¹protein.

The activity of L-phenylalanine ammonia-lyase (PAL; E.C. 4.3.1.5.) was determined by the method of Zucker (1965). Aliquots of 0.3 – 0.5 mL of the crude extract were mixed with 1.9 – 2.1 mL boric acid-borax buffer 0.2 mol L⁻¹, pH 8.8. The probes were thermostated at 36 °C. The reaction started after the addition of 0.6 mL L-phenylalanine at a concentration of 0.1 mol L⁻¹. After 15 min of incubation at a constant temperature spectrophotometric reading began at 290 nm.

The enzyme activity was calculated based on the molar extinction coefficient of *t*-cinnamic acid at 290 nm = $10^4 \text{ mM}^{-1} \text{ cm}^{-1}$. The specific activity was expressed as Kat Kg⁻¹ prot. (mol s⁻¹).

The diamine putrescine and the polyamines spermine and spermidine were extracted, isolated and quantified according to the method of Flores and Galston (1982) based on direct dansylation, followed by separation of amines using TLC. The chromatographic plates were dried and the dansylpolyamine bands were quantified with an densitometer (Quick Scan – Flur-Vis; Helena Lab., USA). By activating the dansylated compounds at 365 nm, the fluorescence intensity was measured at 507 nm. Quantitative analyses were carried out by integration of peaks referring to each amine, compared with those obtained of p.a. standards.

Statistical analysis

Identity of mean values was checked by *t*-test analyses after analyses of the identity of variances based on the *F*-test using the program Statistica for Windows v. 5.1 (StatSoft Inc., Tulsa, USA).

RESULTS AND DISCUSSION

The obtained results indicate that except for the control treatment, there were differences in PAL activity among the four bean cultivars studied. These differences demonstrated a strong dependence on the level of glucose equivalents, especially for BAT and JALO cultivars. PAL activity in the IAC cultivar showed a slight increase with increasing the concentrations of the eliciting solution in the culture medium, mainly for levels of 50 and 100 µg mL⁻¹. The cultivar IAPAR only respond to the highest levels of applied elicitor, 100 and 200 µg mL⁻¹ (Fig. 1). In spite of the treatments with high glucose-equivalents have influenced more the activity of PAL, a decrease of this tendency was observed when the maximum concentration of elicitors (200 µg mL⁻¹) was applied, mainly for IAC, BAT and IAPAR. These results agree with the reported by Campbell and Ellis (1992); Moniz de Sá et al. (1992); Messner et al. (1991) for the same enzyme in other species.

Working with bean cells suspension, Dixon et al. (1981) observed a dose-response effect (elicitor concentration isolated from *Colletotrichum lindemuthianum*) in the activity of PAL. The authors observed two maxima of the enzyme activity in function to the application of smaller doses of elicitors (17.5 and 50 µg equivalent-glucose mL⁻¹). The activity reduced for the treatments with high concentration of glucose-equivalent. According to Albersheim and Valent (1978) the dose-response effect can be explained with the connection of the elicitors to specific sites at the plasmatic membrane of the host cells, when some competition can be established.

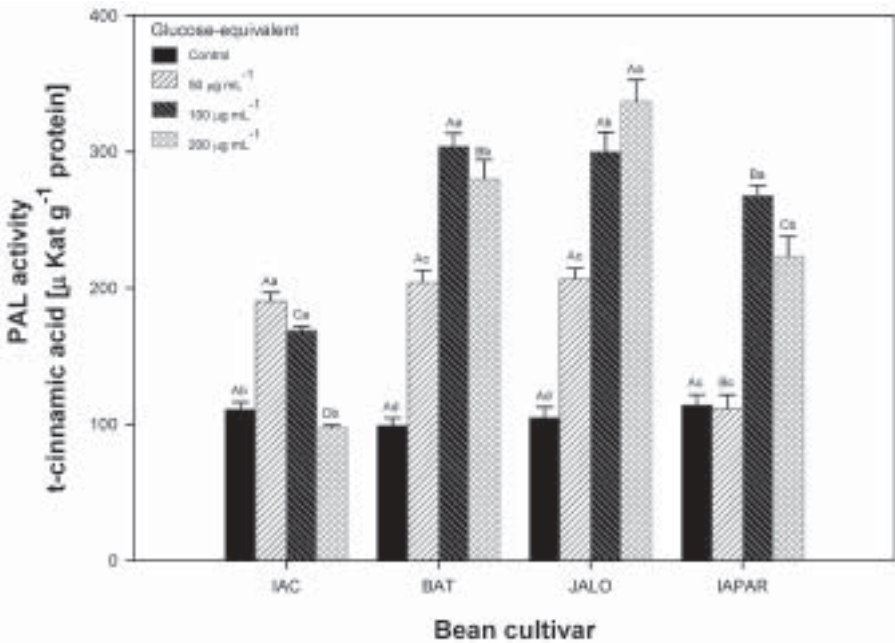

Fig. 1. Changes in the catalytic activity of phenylalanine ammonia-lyase in suspension-cultured *Phaseolus vulgaris* cells 48 h after treatment with an elicitor released from the wall of *Fusarium oxysporum*. Significant differences between means (extracts from 6 individual probes per treatment) of the different cultivars or different treatments within the genotypes are marked with different letter (Tukey test, 5%); Vertical bars indicate \pm SE.

This competition can happen mainly due to the presence of low molecular weight carbohydrates among the components of PAL elicitors.

The dose-response effects for eliciting plant tissues can vary according to the studied species and the conditions of the treatments. Potato protoplasts presented hypersensitivity response, with log – linear model, when elicited with *P. infestans* (Doke and Tomiyama, 1980); Albersheim and Valent (1978) observed linear response for the glyceollin accumulation in soybean cells treated with *P. megasperma* var. Sojae (PMS). A hyperbolic curve of the PAL activity was observed by Ebel et al. (1976), after elicitation of soybean cell suspensions with PMS. More complex relationships were observed by Dixon and Lamb (1979) and Lawton et al. (1980) for the induction of PAL and phaseollin accumulation, in bean cell suspensions treated with *Colletotrichum lindemuthianum*.

Some works (Lawton et al., 1983; Bell et al., 1984; Hahlbrock and Schell, 1989; Campbell and Ellis, 1992) point the enzyme PAL as the precursor of the lignin biosynthesis, phenols, flavonoids and phytoalexins by plant tissues, related to the plant response system against microorganisms, insects and other stress factors.

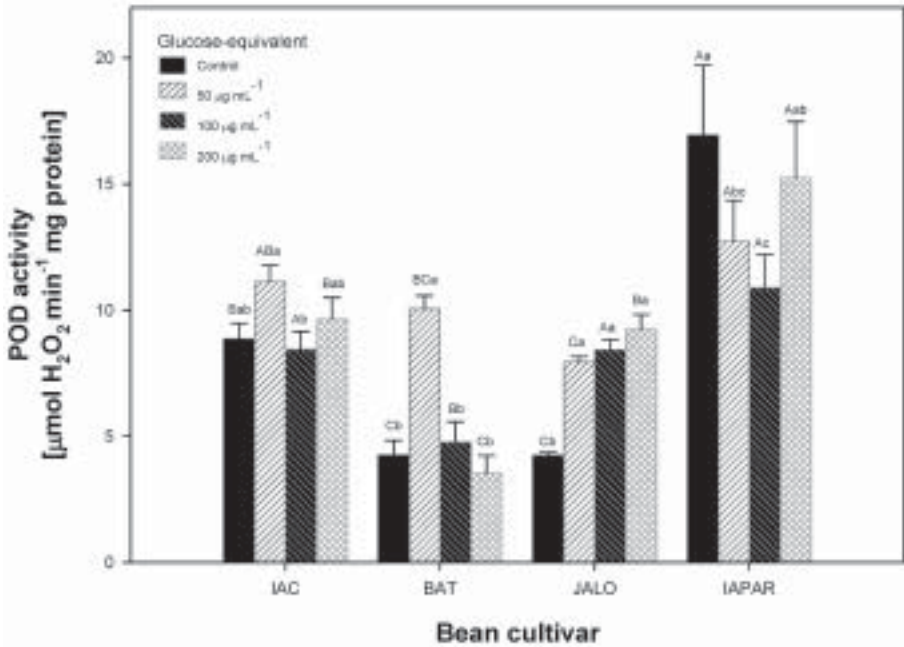

Fig. 2. Changes in the peroxidase activity in suspension-cultured *Phaseolus vulgaris* cells 8 h after treatment with an elicitor released from the wall of *Fusarium oxysporum*. Significant differences between means (extracts from 6 individual probes per treatment) of the different cultivars or different treatments within the genotypes are marked with different letter (Tukey test, 5%); Vertical bars indicate \pm SE.

An induction was observed at the highest level of elicitors application in the cv. JALO. As for cv. BAT, with the exception of $50 \mu\text{g mL}^{-1}$, there were not significant differences compared to the control. A decrease of enzyme activity due to all treatments was observed to the cv. IAPAR, compared to the control. The cells of cv. IAC didn't present differences among the treatments, compared to untreated cells (Figure 2).

The observed results with beans could reflect the cell response capacity due to the fungi cell wall hydrolisate applied. The potential of the cv. JALO is clear, presenting increase of activity of peroxidases in all applied treatments. Regarding the enzyme PAL, the cv. JALO also showed the highest activity among the tested materials, and it seems to be the most responsive genotype. The peroxidase activity, in general, increases under different stress conditions, like wounds, fungi infections, salinity, water stress and nutritional disorders, inducing also the lignin increment and production of ethylene (Van Huystee, 1987; Schallenberger, 1994). However, the shift in the activity of the referred enzyme can vary, motivating the discussion about peroxidase active role in the resistance (Moerschbacher, 1992). The peroxidase action could still happen in an indirect way, through the activity of sub-products, which

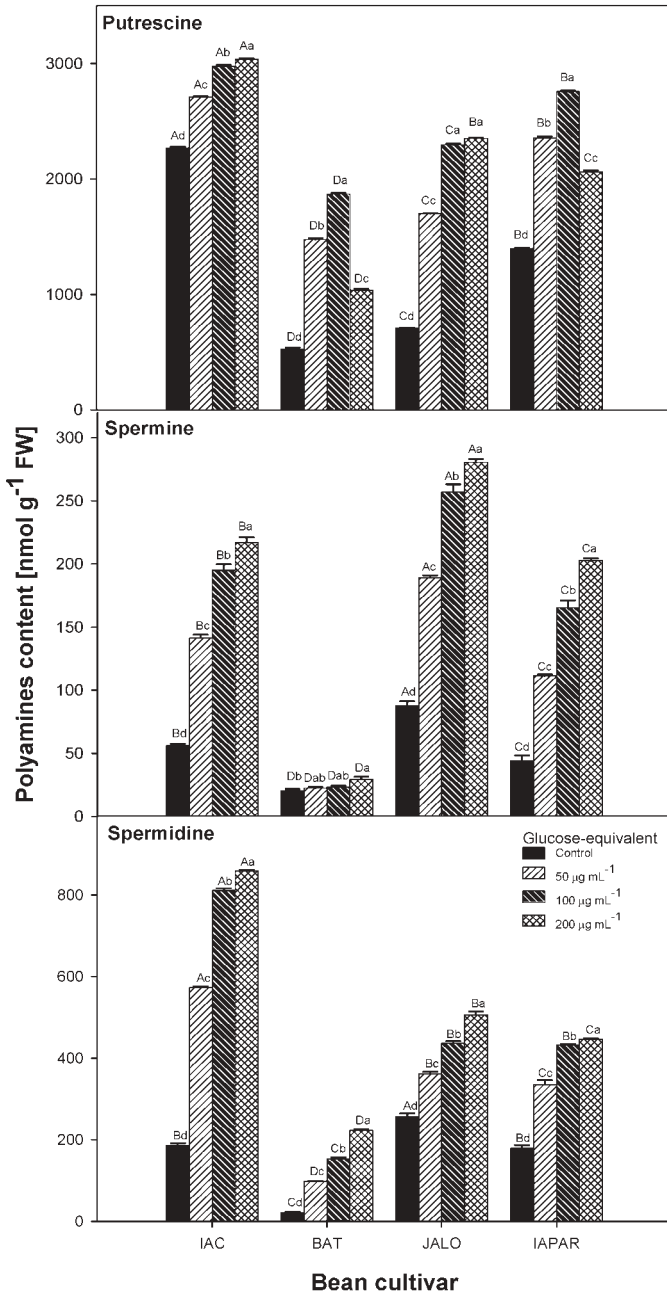

Fig. 3. Content of free polyamines in suspension-cultured *Phaseolus vulgaris* cells 48 h after treatment with an elicitor released from the wall of *Fusarium oxysporum*. Significant differences between means (extracts from 6 individual probes per treatment) of the different cultivars or different treatments within the genotypes are marked with different letter (Tukey test, 5%); Vertical bars indicate \pm SE.

possessed an antimicrobial activity or by inducing the formation of structural barriers. Some mechanisms proposed to explain the peroxidase action and phenoloxidases during the host-pathogen interaction include that these enzymes induce the increase of the production of phenols oxidized at the cell wall (Retig, 1974). This activity, suggests a cell effort for the establishment of a physiochemical barrier, able to isolate the infected area (Urs and Dunleavy, 1975).

Changes of di- and polyamines contents can be expected to occur as a response to tissue infection. In this study, the incubation of bean cells with hydrolyzed *F. oxysporum* cell wall was effective to induce the biosynthesis of di- and polyamines for all studied genotypes (Figure 3). The accumulation of putrescine was clear, which was induced with levels higher than those of polyamines, mainly for the cv. IAC, JALO and IAPAR. Elicitation of cells with 100 $\mu\text{g mL}^{-1}$ of glucose-equivalent was the most effective treatment for accumulation of putrescine. The polyamines spermine and spermidine accumulation presented only slight increases, especially in the highest glucose-equivalent concentration, with significant accumulation of these polyamines in cv. IAC and spermine in the case of cv. JALO. Plant polyamines (PA) biosynthesis in response to biotic stress agents has been an object of few studies, although some works about these interactions indicate that the metabolism of PA can play important role in the adaptation of plants to these agents (Walters, 2000).

Stoessl and Unwin (1978) demonstrated that the formation of coumaroyl-*agmatine* inhibited the fungi spores' germination in barley and this condition probably contributed to the resistance of barley plantlets to the fungi infection.

The formation of these compounds is catalyzed by the enzyme *agmatine coumaroyl-transferase*, which uses coumaroyl-CoA and *agmatine* (polyamine) as main substrate (Bird and Smith, 1983). In the present study, it was verified that the induction of the enzyme PAL and the formation of 4-coumaroyl-CoA, probably favored the biosynthesis of substrate for the diamine formation and conjugated polyamines.

This hypothesis can be upheld by referring to the experiments conducted by Berlin & Forche (1981). Working with a *Nicotiana tabacum* cell culture, they observed that the increase of *t*-cinnamic acid synthesis (product of the PAL, utilizing *L-Phe* as substrate) was accompanied with increase of synthesis of *cinnamyl-putrescine*, which could exercise the function of *phytoalexine*.

In conclusion, the results of the present experiment suggest differences among the cultivars with respect to accumulation of di- and polyamines in elicited bean cells. This seems to indicate that the polyamines do, in fact, some function in the plants adaptation biotic stress.

The treatments induced the cells to accumulate di- and polyamines, principally for IAC and JALO. The accumulation of polyamines was greater in the treatments with higher concentration of elicitors.

The activity of the studied enzymes (PAL and peroxidases) presented different

levels of induction according to tested cultivar, with a strong dose-response relationship, mainly for IAPAR, BAT and IAC.

References

- Albersheim, P., B.S. Valent, 1978. Host-pathogen interactions in plants, *J. Cell Biol.*, 78, 627-643.
- Allain, C.C., L.C. Poon, C.S.G. Chan, W. Richmond, P.C. Fu, 1974. Enzymatic determination of total serum cholesterol, *Clin. Chem.*, 20, 470-475.
- Ayers, A.R., J. Ebel, F. Finelli, P. Albersheim, 1976. Host-pathogen interactions. IX. Quantitative assays of elicitor activity and characteristics of the elicitor present in the extracellular medium of cultures of *P. megasperma* var. *sojare*, *Plant Physiol.*, 57, 751-759.
- Bell, J.N., R.A. Dixon, J.A. Bailey, P.M. Rowell, C.J. Lamb, 1984. Differential induction of chalcone synthase mRNA activity at onset of phytoalexin accumulation in compatible and incompatible plant-pathogen interactions, *Proc. Natl. Acad. Sci. United States of America*, 81, 3384-3388.
- Berlin, J., E. Forche, 1981. DL-Difluoromethylornithine causes enlargement of cultured tobacco cells, *Z. Pflanzenphysiol.*, 101, 277-282.
- Bird, C.R., T.A. Smith, 1983. Agmatine coumaroyltransferase from barley seedlings, *Phytochemistry*, 22, 2401-2403.
- Bollen, G.J., 1985. Lethal temperatures of soil fungi. In: Ecological a management of soiborne plant pathogens. Ed. C.A. Parker, *Proc. Am. Phytopathol. Soc.- St. Paul*, 191-193.
- Bradford, M.M., 1976. A rapid and sensitive method for the quantification of microgram quantities of protein utilizing the principle of protein-dye-binding, *Anal. Biochem.*, 72, 248-254.
- Broetto, F. Effect of saline and biotic stress on the metabolism of callus and cell suspension of bean (*Phaseolus vulgaris* L.), 1995. 124p. (PhD. Thesis). Piracicaba.
- Broetto, F., U. Luttge, R. Ratajczak, 2002. Influence of light intensity and salt treatment on mode of photosynthesis and enzymes of the antioxidative response system of *Mesembryanthemum crystallinum*, *Funct. Plant Biol.*, 29, 13-23.
- Campbell, M.M., B.E. Ellis, 1992. Fungal elicitor-mediated responses in pine cell cultures, *Planta*, 186, 409-417.
- Dixon, R.A., C.J. Lamb, 1979. Stimulation of de novo synthesis of L-phenylalanine ammonia-lyase in relation to phytoalexin accumulation in *Colletotrichum lindemuthianum* elicitor-treated cell suspension cultures of French bean (*Phaseolus vulgaris*), *Biochem. Biophys. Acta*, 586, 127-140.
- Dixon, R.A., P.M. Dey, D.L. Murphy, I.M. Whitehead, 1981. Dose responses for *Colletotrichum lindemuthianum* elicitor-mediated enzyme induction in French bean cell suspension cultures, *Planta*, 151, 272-280.
- Doke, N., K. Tomiyama, 1980. Suppression of the hypersensitive response of potato tuber protoplasts to hyphal wall components by water soluble glucans isolated from *Phytophthora infestans*, *Physiol. Plant Pathol.*, 16, 177-186.

- Dubois, M., K.A. Gicles, J.K. Hamilton, P.A. Rebers, F. Smith, 1956. Colorimetric method for determination of sugars and related substances, *Anal. Chem.*, 28, 350-356.
- Ebel, J., A.R. Ayers, P. Albersheim, 1976. Host-pathogen interactions XII. Response of suspension-cultured soybean cells to the elicitor isolated from *Phytophthora megasperma* var. *sojae*, a fungal pathogen of soybeans, *Plant Physiol.*, 57, 775-779.
- Espelie, K.E., V.R. Franceschi, P.E. Kolattukudy, 1986. Immunocytochemical localization and time course of appearance of an anionic peroxidase associated with suberization in wound-healing potato tuber tissue, *Plant Physiol.*, 81, 487-492.
- Flores, H.E., A.W. Galston, 1982. Polyamines and plant stress. Activation of putrescine biosynthesis by osmotic shock, *Science*, 217, 1259-1261.
- Flores, H.E., P. Filner, 1985. Metabolic relationships of putrescine, GABA and alkaloids in cell and root cultures. In: *Primary and Secondary Metabolism of Plant Cell Cultures*, Eds. K.H. Newman, W. Barz, E. Reinhard, New York-Springer, 37-42.
- Gleitz, J. Die regulation der lichtinduzierten anthocyan synthese in zellkulturen von *Daucus carota* L., 1989. 193p. (Dissertation-Universität Tübingen). Tübingen.
- Greeland, A.J., D.H. Lewis, 1984. Amines in barley leaves infected by brown rust and their possible relevance to formation of green islands, *New Phytol.*, 96, 283-91.
- Hahlbrock, K.; D. Schell, 1989. Physiology and molecular biology of phenylpropanoid metabolism, *Annu. Rev. Plant Physiol. Mol. Biol.*, 40, 347-369.
- Köhle, H.; W. Jeblick, F. Poten, W. Blaschek, H. Krauss, 1985. Chitosan elicited callose synthesis in soybean cells as a Ca^{+2} -dependent process, *Plant Physiol.* 77, 544-561.
- Kuc, J.; J.S. Rusch, 1985. Phytoalexins, *Arch. Biochem. Biophys.*, 236, 455-472.
- Lawton, M.A.; A.R. Dixon, C.J. Lamb, 1980. Elicitor modulation of the turnover of L-Phenylalanine ammonia-lyase in French beans cell suspension cultures, *Biochim. Biophys. Acta*, 633, 162-175.
- Lawton, M.A.; A.R. Dixon, K. Hahlbrock, C. Lamb, 1983. Elicitor induction of mRNA activity. Rapid effects of elicitor on phenylalanine ammonia-lyase and chalcone synthase mRNA activities in bean cells, *Eur. J. Biochem.*, 130, 131-139.
- Messner, B., M. Boll, J. Berdt, 1991. L-Phenylalanine ammonia-lyase in suspension culture cells of spruce (*Picea abies*), *Plant Cell, Tissue and Organ Cult.*, 27, 267-274.
- Moerschbacher, B.M., 1992. Plant peroxidases: involvement in response to pathogens. In: *Plant peroxidases 1980-1999*, Eds C. Penel, T. Gaspar, H. Greppin, University of Geneva, 91-99.
- Moniz de Sá, M., R. Subramaniam, F.E. Williams, C.J. Douglas, 1992. Rapid activation of phenylpropanoid metabolism in Elicitor-treated hybrid Poplar (*Populus trichocarpa* Torr. and GRAY X *Populus deltoides* Marsh) suspension-cultured cells, *Plant Physiol.*, 98, 728-737.
- Murashige, T., F. Skoog, 1962. A revised medium for rapid growth and bioassays with to tobacco tissue culture, *Physiol. Plant.*, 15, 473-493.
- Nascimento, S.R.C., A.C. Kurozawa, A.C. Maringoni, 1995. Evaluation of physiologic races of *Fusarium oxysporum* F. sp. *Phaseoli*, *Braz. Phytopathol.*, 20, 214-217.
- Pascholati, S.F., B. Leite, 1995. Host: resistance mechanism. In: *Phytopathology Manual: principles and concepts*, v.1, Eds A. Bergamin filho, H. Kimati, L. Amorim, Ceres:São Paulo, 417-53.

- Retig, N., 1974. Changes in peroxidase and polyphenoloxidase associated with natural and induced resistance of tomato to *Fusarium* wilt., *Physiol. Plant Mol. Pathol.*, 4, 145-150.
- Ribeiro, C.A.G., S. Ferraz, 1984. Varietal resistance of bean (*Phaseolus vulgaris* L.) to *Fusarium oxysporum* f. sp. *Phaseoli*, *Braz. Phytopathol.*, 9, 37-44.
- Samborski, D.J., R., Rohringer, 1970. Abnormal metabolites of wheat: Occurrence, isolation and biogenesis of 2-hydroxyputrescine amides, *Phytochemistry*, 9, 1939-1945.
- Schallenberger, E. Factors that permit the attack of the citrus plants by beetles, 1994. 110p. (Master dissertation), Botucatu.
- Schell, D., J.E. Parker, 1990. Elicitor recognition and signal transduction in plant gene activation, *Z. Naturforsch.*, 450, 569-575.
- Siegel, B.Z., 1993. Plant peroxidase: an organismic perspective, *Plant Growth Regul.*, 12, 303-12.
- Slocum, R.D., R. Kaur-Sawhney,, A.W. Galston, 1984. The physiology and biochemistry of polyamines in plants, *Arch. Biochem. Biophys.*, 235, 283-303.
- Smith, T. A., G. R. Best, 1978. Distribution of the hordatines in barley, *Phytochemistry*, 17, 1093-1098.
- Stoessl, A., C.H. Unwin, 1978. The antifungal factors in barley. V. Antifungal activity of the hordatines, *Can. J. Bot.*, 48, 465-470.
- Urs, N.V.R., D.M. Dunleavy, 1975. Enhancement of bactericidal activity of a peroxidase system by phenolic compounds, *Phytopathol.*, 65, 686-690.
- Van Huystee, R.B., 1987. Some molecular aspects of plant peroxidase biosynthetic studies, *Annu. Rev. Plant Physiol.*, 36, 205-19.
- Vance, C.P., Kirk, T.K., Sherwood, R.T., 1980. Lignification as a mechanism of disease resistance, *Annu. Rev. Phytopathol.*, 18, 259-298.
- Walters, D.R., 2000. Polyamines in plant-microbe interactions, *Physiol. Mol. Plant Pathol.*, 57, 137-146.
- Walters, D.R., M.A. Wylie, 1986. Polyamines in discrete regions of barley leaves infected with the powdery mildew fungus, *Erysiphe graminis*, *Physiol. Plant.*, 67, 630-633.
- Zucker, M., 1965. Induction of Phenylalanine Ammonia-Lyase by light and its relation to chlorogenic acid synthesis in potato tuber tissue, *Plant Physiol.*, 40, 779-784.

Brief communication**ASCORBIC ACID QUANTIFICATION IN MELON SAMPLES – THE IMPORTANCE OF THE EXTRACTION MEDIUM FOR HPLC ANALYSIS**

Bárbara Albuquerque^{1,*}, Fernando C. Lidon¹ and A. Eduardo Leitão²

¹ Unidade de Biotecnologia Ambiental, Faculdade de Ciências e Tecnologia da Universidade Nova de Lisboa, Quinta da Torre, 2829-516 Caparica, Portugal

² Departamento de Ciências Naturais, Instituto de Investigação Científica Tropical, Apartado 3014, 1301-901 Lisboa, Portugal

Received 10 November 2005

Summary. Two high-performance liquid chromatography (HPLC) methods for ascorbic acid (AA) quantification were compared in three cultivars of melon (*Cucumis melo* L.) fruits. Both procedures were analogous except for the extraction medium used: 6 % *meta*-phosphoric acid and 3 % citric acid. The general conclusion is that 3 % citric acid is a better extraction medium compared to 6 % *meta*-phosphoric acid and it can be used for ascorbic acid quantification analyses in melon samples.

INTRODUCTION

Fresh fruits and vegetables are significant sources of dietary vitamin C (Wills et al., 1984). A dose of 100 – 200 mg daily has been highly recommended since stress in modern life is known to increase the requirements for this vitamin (Lee and Kader, 2000). It is defined as the generic term for all compounds exhibiting biological activity of L-ascorbic acid (AA). This is the biologically active form, but L-dehydroascorbic acid (DHA), an oxidation product, also exhibits biological activity.

There are a large amount of analytical methods for ascorbic acid quantification based mostly on AA antioxidant characteristics (Farajzadeh and Nagizadeh, 2003). The most common method is the oxidative titration with 2,6-dichlorophenol-indophenol (Official Methods of Analysis, 1980). This is a rapid method, but its use is diffi-

* Corresponding author, e-mail: baba_albuquerque@hotmail.com

cult in colored solutions, due to interference of other oxidizing agents. Furthermore, DHA can not be estimated (Wimalasiri and Wills, 1983). The high-performance liquid chromatography (HPLC) technique deserves an increasing interest mainly due to its rapidity, selectivity and specificity proprieties (Sood et al., 1976; Bui-Nguyen, 1980; Rose and Nahrwold, 1981; Haddad and Lau, 1984; Romero-Rodrigues et al., 1992). It allows a rapid and simultaneous estimation of AA and DHA in some foods and other biological materials (Wills et al., 1984).

Auto-oxidation of AA by air oxygen is greatly decreased by an acidic medium (Romero-Rodrigues et al., 1992) which is required to stabilize AA (Wimalasiri and Wills, 1983). Trichloroacetic, metaphosphoric, oxalic or acetic acids are commonly used as extraction media with further purposes like better AA extraction and protein precipitation (Romero-Rodrigues et al., 1992).

In this study, we compared two different methods for ascorbic acid quantification. The first method is that of AOAC (Official Methods of Analysis, 1980), commonly used (Smith, 1986; Romero-Rodrigues et al., 1992; Bradbury and Singh, 1986) which requires 6 % *meta*-phosphoric acid as the extraction medium. The second method is the Wimalasiri and Wills method in which 3 % (w/v) citric acid, is used as a medium for AA extraction (Wimalasiri and Wills, 1983).

Both methods have been applied on three cultivars of melon fruit (*Cucumis melo* L.): Brazilian *Branco*, Spanish *Pele de Sapo* and winter *Tendral* melons, as the cultivars with huge acceptance (Albuquerque, 2004).

MATERIALS AND METHODS

Preparation of samples

Fully ripened fruits of three melon cultivars (*Tendral*, *Pele de Sapo* and *Branco*) were analyzed. Samples of 20 g from 10 fruits were homogenized with 30 ml of extraction medium and centrifuged at 15000 g for 25 min at 4 °C. The slurry was filtered through filter paper Whatman No 4 and then, through a membrane Millipore (0.45 µm). The extraction medium was as follows: 6 % *meta*-phosphoric acid (Merck) for method 1 and 3 % (w/v) citric acid (Merck) for method 2.

HPLC analysis

An aliquot (20 µl) was injected for AA measurement using a Beckman System Gold. The HPLC system consisted of a 126 Beckman pump and a diode array detector (254 nm) operated by a Gold 8.10 software. An Aminex HPX-87H (BioRad) column was used. A flow rate of 0.4 ml min⁻¹ was applied at room temperature with 5 mM H₂SO₄ (pH 2.3) as a mobile phase. Three replicates of each sample were injected. An internal standard of AA (Sigma-Aldrich) was used.

Citric acid quantification

Acid extraction was carried out as described by Hudina and Stampar (2000). Samples of 20 g from 10 fruits were dissolved in 100 ml distilled water and centrifuged at 15000 g for 15 min at 4 °C. Filtration was carried out using Whatman No 4 filters and Millipore (0.45µm) membranes. Citric acid was identified and quantified by HPLC using a Beckman Gold 168 diode-array detector. An Aminex HPX 87H (BioRad) column was used. A flow rate of 0.5 ml min⁻¹ was applied at room temperature to a mobile phase of 5 mM H₂SO₄. An internal standard of citric acid (Merck) was used.

RESULTS AND DISCUSSION

Since DHA can be easily converted into AA in the human body, it is important to measure both forms of vitamin C (AA and DHA) (Lee and Kader, 2000). In our experiment, only AA was measured since at harvest, DHA represents less than 2 % of total vitamin C (Wills et al., 1984). In one and the same sample AA content was totally distinct using both methods for all cultivars (Fig. 1). In addition, both methods correlated in 96 %.

Extraction with 3 % citric acid was more efficient and if we consider the value obtained as total, extraction with 6 % *meta*-phosphoric acid showed 56.1 %, 35.3 % and 12.7 % efficiency, for *Branco*, *Pele de Sapo* and *Tendral* samples, respectively.

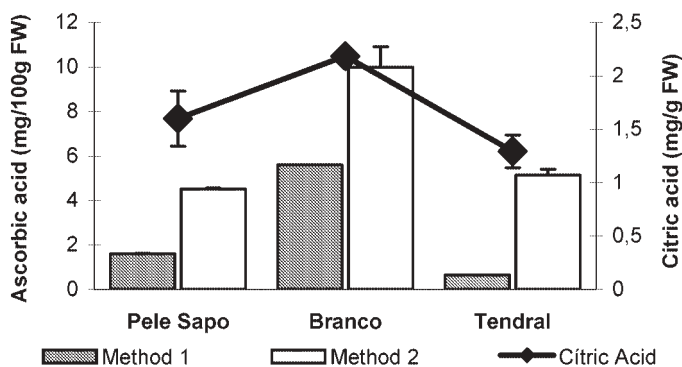

Fig. 1. Ascorbic acid content in three melon cultivars using two methods and citric acid content in different melon cultivars. Each value represents the mean of three replicates ± standard error. Different letters indicate significant differences in a multiple range analysis for 95 % confidence level.

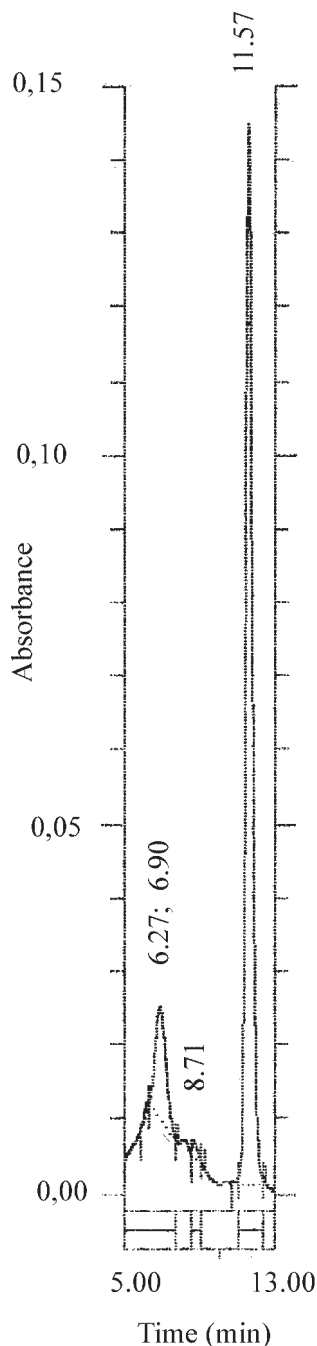

Fig. 2. – Chromatogram of AA in *Branco* melon extract in 3 % citric acid.

These extraction efficiencies might be explained by the different citric acid content in the cultivars tested (Fig. 1). *Branco* melon has higher citric acid concentration, in contrast to *Tendral* melon, the data being significantly different. Our data agree with the above trend. In fact, if ascorbic acid content correlated with the citric acid concentration for each melon cultivar sample, a clear link could be seen ($r^2 = 0.97$). For example, in a *Branco* melon sample, extraction with 6 % *meta*-phosphoric acid resulted in 5.61 mg of AA in 100 g FW while extraction with 3 % citric acid (Fig. 2) resulted in 9.08 mg of AA in 100 g FW.

It has been reported that AA extraction solution containing 6 % *meta*-phosphoric acid can be stored up to 8 h at 4 °C before HPLC analysis (Smith, 1986) while AA extraction solution with 3 % citric acid remains stable for 3 h at room temperature (Wimalasiri and Wills, 1983). Both samples are therefore stable during the procedures, although the different extraction efficiencies found could not be explained. The ability of some compounds to form ring structures with metal ions (chelation), thus preventing metal ions from reacting with other materials or from acting as a catalyst, might justify our data. Citric acid is the strongest chelating agent of the common food acids and can enhance the effectiveness of AA antioxidant properties by providing a synergistic effect (Kuntz, 1993). So, the addition of citric acid provides a more stable environment for the AA.

Vitamin C content in melon cultivars might fluctuate between 6 and 60 mg in 100 g FW (Odet, 1991). The content of this vitamin in fruits and vegetables varies between cultivars and tissues (Lee and Kader, 2000). Our general conclusion based on the results presented is that 3 % citric acid is a better extraction medium when compared to 6 % *meta*-phosphoric acid for AA analyses in melon samples. The application of both procedures with other samples would be of great interest.

Acknowledgements: This work was supported by the Project AGRO DE and D No 191 from EAN-INIAP, Portugal.

References

- Albuquerque, B., 2004. Avaliação da qualidade e regulação dos mecanismos de senescência durante a conservação do melão *Tendral* de Campo Maior, Master Thesis, Universidade Nova de Lisboa, Lisboa, p. 148.
- Bradbury, J.H., U. Singh, 1986. Ascorbic acid and dehydroascorbic acid content of tropical root crops from the south pacific. *J. Food Sci.*, 51, 975-987.
- Bui-Ngugen, M.H., 1980. Application of high performance liquid chromatography to the separation of ascorbic acid from isoascorbic acid. *J. Chromatogr.*, 196, 163.
- Farajzadeh, M.A., S. Nagizadeh, 2003. A simple and reliable spectrophotometric method for the determination of ascorbic acid in pharmaceutical preparations. *J. Anal. Chem.*, 58, 927-932.
- Haddad, P.R., J. Lau, 1984. The use of high performance liquid chromatography for the analysis of ascorbic acid and dehydroascorbic acid in orange juice and powdered orange drink. *Food Technol. (Australia)*, 36, p.46.
- Hudina, M., F. Stampar, 2000. Free sugar and sorbitol content in pear (*Pyrus communis* L.) cv. Williams during fruit development using different treatments. *Acta Hort.* 514, 269-274.
- Kuntz, L. A., 1993. Acid Basics, Weeks Publishing Company.
- Lee, S.K., A.A. Kader, 2000. Preharvest and postharvest factors influencing vitamin C content of horticultural crops. *Postharvest Biol. Technol.*, 20, 207-220.
- Odet, J. 1991. Le melon. Ctifl.
- Official Methods of Analysis, Association of Official Analytical Chemists, Washington, DC, 13th Ed., pp. 746-747, 1980.
- Romero-Rodrigues, A., L.V. Oderiz, J.L. Hernandez, J.S. Gandara, 1992. Comparaison de deux méthodes de dosage par CLHP de l'acide ascorbique dans *Carica pentagona*. *Sci. Aliments*, 12, 593-600.
- Rose, R.C., D.L. Nahrwold, 1981. Quantitative analysis of ascorbic acid and dehydroascorbic by HPLC in food and biological material. *Anal. Biochem.*, 114, p.140.
- Smith, S.M., 1986. Measurement of the quality of apples – Recommendations of an ECC Working Group, East Malling Research Station, UK.
- Sood, S.P., L.E. Sastosi, D.P. Wittmer, W.C. Haney, 1976. High pressure liquid chromatography determination of ascorbic acid in selected foods and multivitamin products. *Anal. Chem.*, 48, 796.
- Wills, R.B.H., P. Wimalasiri, H. Greenfield, 1984. Dehydroascorbic acid levels in fresh fruit and vegetables in relation to total vitamin C activity. *J. Agric. Food Chem.*, 32, 836-838.
- Wimalasiri, P., R.B.H. Wills, 1983. Simultaneous analysis of ascorbic acid and dehydroascorbic acid in fruit and vegetables by high performance liquid chromatography. *J. Chromatogr.*, 256, 368-371.